

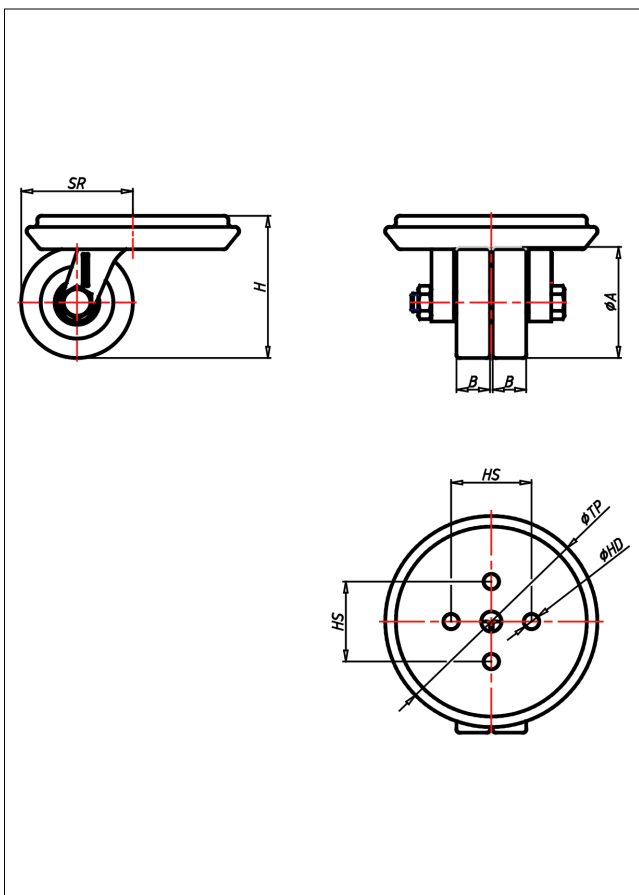

2SL-P/Z/WUDPK/CI

Lenkrolle



2SL



RAD CI	RAD P	RAD WUDPK
<ul style="list-style-type: none"> hohe Tragkraft bei geringer Bauhöhe leichter Lauf durch großes Schwenklager 	<p>Doppellenkrolle aus Stahl verzinkt und Grauguss, Kugellager 62</p>	<p>CI: Rad aus Stahl P: Rad aus Polyamid 6 Z: Stahlrad mit Vulkopanbereifung WUDPK: Rad aus Vulkopan</p>

Technische Details

ORDERNO (Artikel-nummer)	2SL 50 CI
WDAB (Rad-Ø A x Breite B / mm)	50x14+14
LC (Tragkraft / kg)	270
H (Bauhöhe H / mm)	64
TP (Plattengröße / mm)	95
HS (Lochabstand / mm)	36x36
HD (Loch-Ø / mm)	6.8
SR (Schwenkradius / mm)	50
WB (Radlager)	Gleitlager