

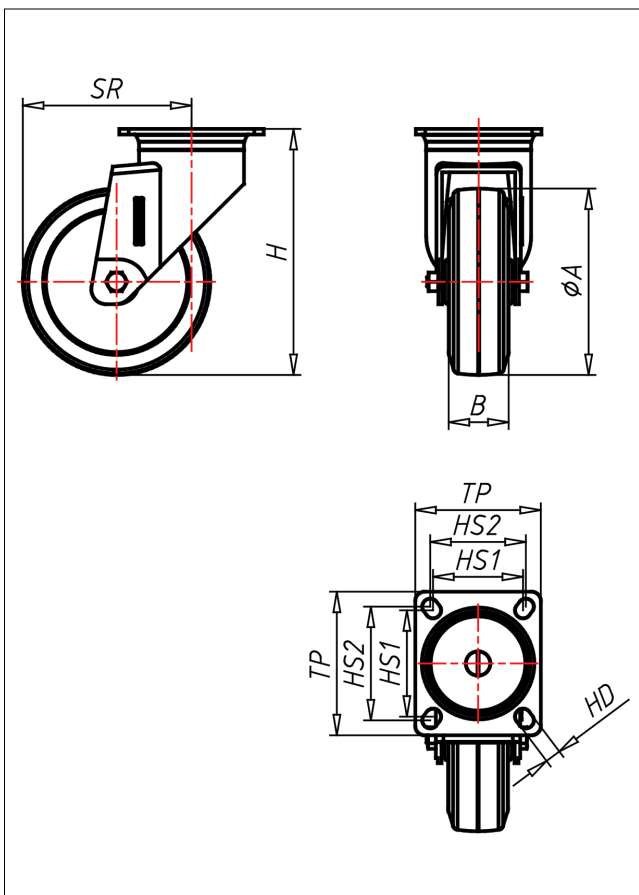

330LXP-EL

Lenkrolle



330LXP-EL



NEU!

Lenkrolle Swivel Castor	Lenkrolle mit Totfallstiller Swivel Castor with total lock	
<ul style="list-style-type: none"> elektrisch leitfähig Widerstand <math><10^{-12}</math> geräuscharmer Lauf großer Fahrkomfort beständig gegen verdünnte Säuren 	<ul style="list-style-type: none"> zweifaches Kugellager - vernietet, Radschase verschraubt - gesichert, alle Teile aus Edelstahl rostfrei 	<p>Auswahlhilfe Selection Criteria</p> <ul style="list-style-type: none"> leicht lenkend/swivels easily <input type="checkbox"/> verschleißarm/wear resistant <input type="checkbox"/> stoßfest/shock proof <input type="checkbox"/> bodenschonend/floor protective <input type="checkbox"/> witterungsbeständig/weather proof <input type="checkbox"/>
<p>Vollgummi oder TPE <i>spurtief</i> Folge Stahlblech oder Polyamid 6 → Seite/Page 355</p>	→ Seite/Page 185	

Technische Details

ORDERNO (Artikelnummer)	330LXK PT 102 ELKX
WDAB (Rad-Ø A x Breite B / mm)	100x32
LC (Tragkraft / kg)	90
H (Bauhöhe H / mm)	132
TP (Plattengröße / mm)	95x70
HS (Lochabstand / mm)	75x50
HD (Loch-Ø / mm)	11
SR (Schwenkradius / mm)	90
WB (Radlager)	Kugellager