

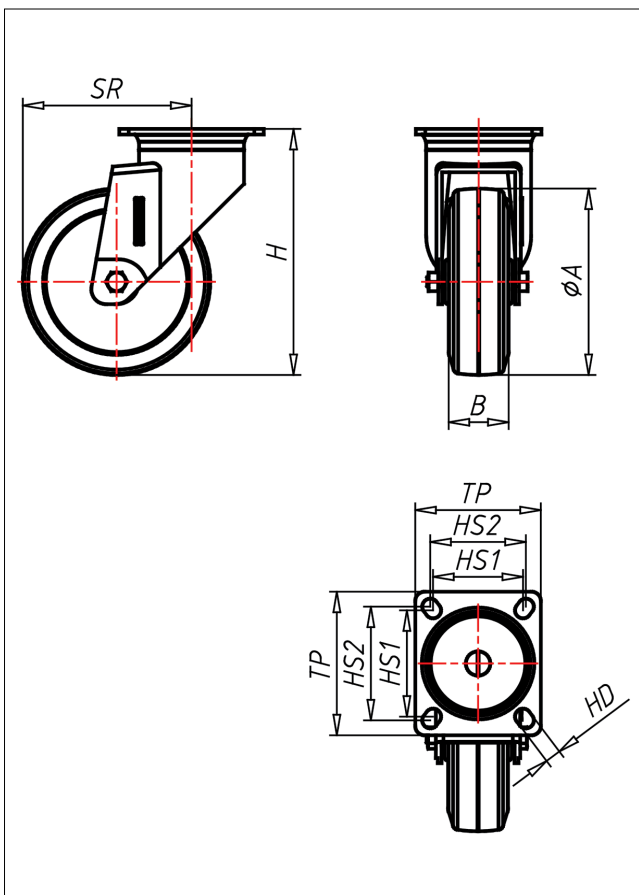

# 330LXP-EL

## Lenkrolle



330LXP-EL



**NEU!**

Lenkrolle Swivel Castor	Lenkrolle mit Totfeststeller Swivel Castor with total lock	
<ul style="list-style-type: none"> <li>elektrisch leitfähig</li> <li>Widerstand &lt;math&gt;&lt;10^{-12}&lt;/math&gt;</li> <li>geräuscharmer Lauf</li> <li>großer Fahrkomfort</li> <li>beständig gegen verdünnte Säuren</li> </ul>	<ul style="list-style-type: none"> <li>zweifaches Kugellager - vernietet, Radschae verschraubt - gesichert, alle Teile aus Edelstahl rostfrei</li> </ul>	<p>Auswahlhilfe Selection Criteria</p> <ul style="list-style-type: none"> <li>leicht lenkend/swivels easily</li> <li>verschleißarm/wear resistant</li> <li>staubfest/dustproof</li> <li>bodenschonend/floor protective</li> <li>witterungsbeständig/weather proof</li> </ul>
<p>Vollgummi oder TPE <b>spurtrot</b>            Folge Stahlblech oder Polyamid 6            → Seite/Page 355</p>	→ Seite/Page 185	

### Technische Details

ORDERNO (Artikelnummer)	330LXK PT 127 ELKX
WDAB (Rad-Ø A x Breite B / mm)	125x32
LC (Tragkraft / kg)	100
H (Bauhöhe H / mm)	158
TP (Plattengröße / mm)	95x70
HS (Lochabstand / mm)	75x50
HD (Loch-Ø / mm)	11
SR (Schwenkradius / mm)	102.5
WB (Radlager)	Kugellager