

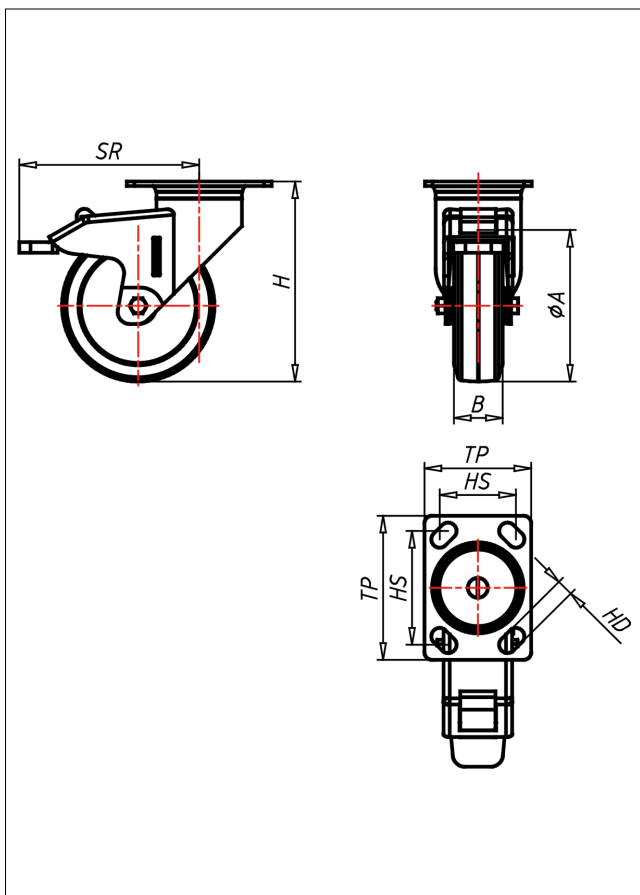

331LXP-EL

Lenkrolle mit Totalfeststeller

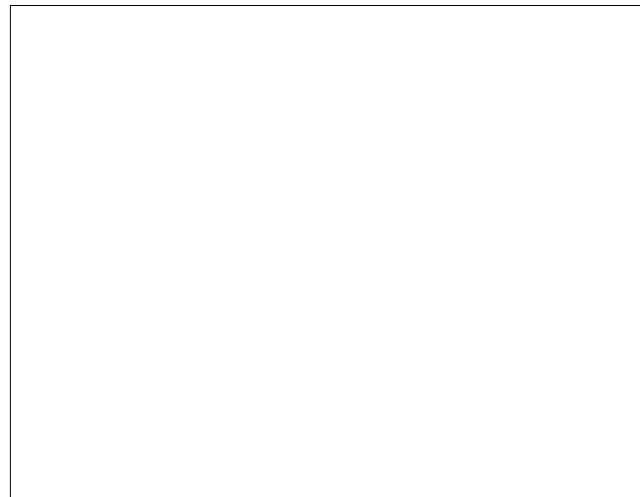
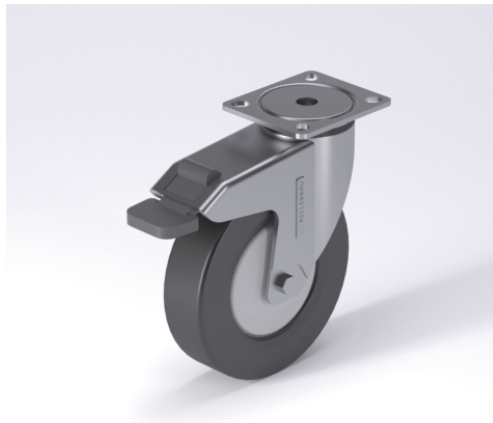

330LXP-EL



NEU!

Lenkrolle Swivel Castor	Lenkrolle mit Totalfeststeller Swivel Castor with total lock	
<ul style="list-style-type: none"> elektrisch leitfähig Widerstand <math><10^{-2}</math> geruscharmer Lauf großer Fahrkomfort beständig gegen verdünnte Säuren 	<ul style="list-style-type: none"> zwölfaches Kugellager - vernietet, Radachse verschraubt - gesichert, alle Teile aus Edelstahl rostfrei 	<p>Auswahlhilfe Selection Criteria</p> <ul style="list-style-type: none"> leicht lenkend/swivels easily verschleißarm/wear resistant staubdicht/dustproof bodenschonend/floor protective witterungsbeständig/weather proof
<p>Vollgummi oder TPE spurfrei Folge Stahlblech oder Polyamid 6 → Seite/Page 355</p>	→ Seite/Page 185	

Technische Details

ORDERNO (Artikel-nummer)	331LX PT 102 EL
WDAB (Rad-Ø A x Breite B / mm)	100x32
LC (Tragkraft / kg)	90
H (Bauhöhe H / mm)	132
TP (Plattengröße / mm)	77x67
HS (Lochabstand / mm)	57x48/61x51
HD (Loch-Ø / mm)	8,5
SR (Schwenkradius / mm)	118
WB (Radlager)	Polyamid-Gleitlager