

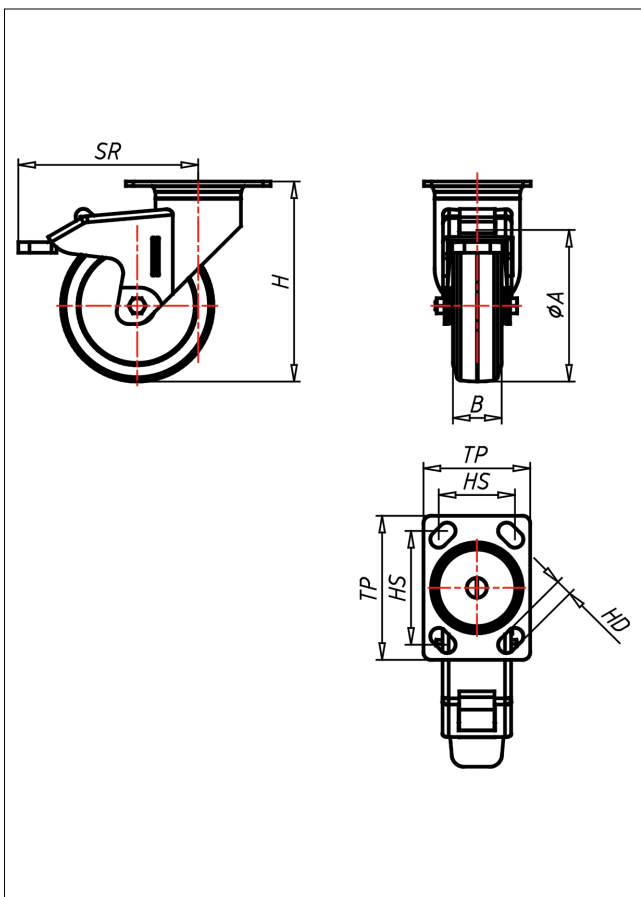

# 331LXP-EL

## Lenkrolle mit Totalfeststeller



330LXP-EL



+60 °C  
-20 °C  
max.  
100 kg



**NEU!**

Lenkrolle Swivel Castor	Lenkrolle mit Totalfeststeller Swivel Castor with total lock	
<ul style="list-style-type: none"> <li>elektrisch leitfähig</li> <li>Widerstand &lt;math&gt;&lt;10^{-12}&lt;/math&gt;</li> <li>geruscharmer Lauf</li> <li>großer Fahrkomfort</li> <li>beständig gegen verdünnte Säuren</li> </ul>	<ul style="list-style-type: none"> <li>zwölfaches Kugellager - vernietet, Radachse verschraubt - gesichert, alle Teile aus Edelstahl rostfrei</li> </ul>	<p>Auswahlhilfe Selection Criteria</p> <ul style="list-style-type: none"> <li>leicht lenkend/swivels easily</li> <li>verschleißarm/wear resistant</li> <li>staubdicht/dust proof</li> <li>bodenschonend/floor protective</li> <li>witterungsbeständig/weather proof</li> </ul>
<p>Vollgummi oder TPE <b>spurtrot</b> Folge Stahlblech oder Polyamid 6 → Seite/Page 355</p>	<p>→ Seite/Page 185</p>	

### Technische Details

ORDERNO (Artikel-nummer)	331LXK PT 127 ELKX
WDAB (Rad-Ø A x Breite B / mm)	125x32
LC (Tragkraft / kg)	100
H (Bauhöhe H / mm)	158
TP (Plattengröße / mm)	95x70
HS (Lochabstand / mm)	75x50
HD (Loch-Ø / mm)	11
SR (Schwenkradius / mm)	130
WB (Radlager)	Kugellager