

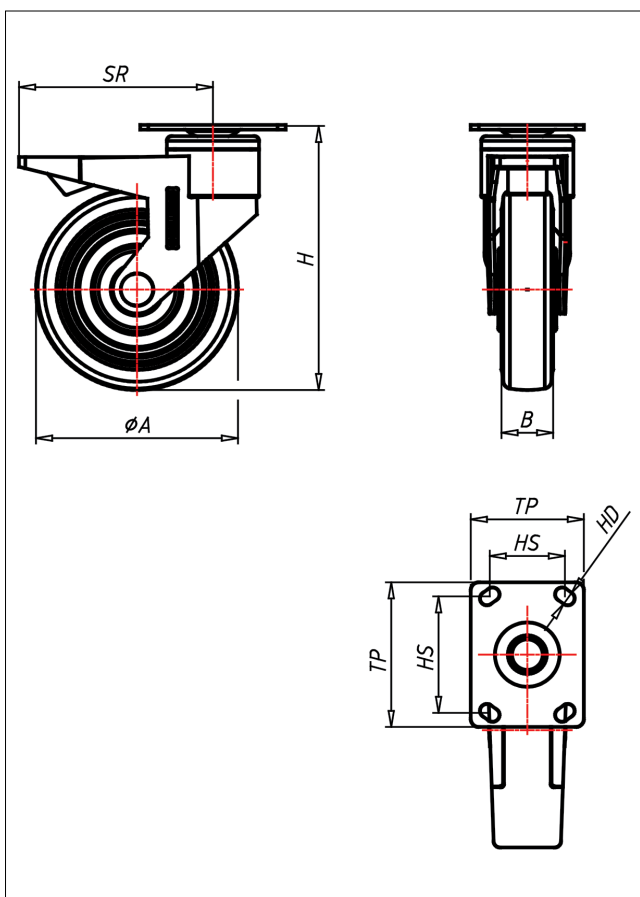

# 801 PT-AELK

## Lenkrolle mit Totalfeststeller



800P-AEL



LENKROLLE	LENKROLLE MIT TOTALFESTSTELLER	LENKROLLE MIT RICHTUNGSFESTSTELLER																				
<ul style="list-style-type: none"> <li>• elektrisch leitfähig</li> <li>• geräuscharmer Lauf</li> <li>• geringer Rollwiderstand</li> <li>• spurfrei</li> <li>• hohe Stoßfestigkeit</li> <li>• sehr beständig gegen viele aggressive Medien</li> </ul>	<p>Polyamid 6-glasfaserverstärkt RAL 7005 Präzisionskugellager DIN 625 ZRS - doppelt gedichtet Radachse verschraubt → Seite 172</p>	<p>AUSWAHLHILFE:</p> <table border="1"> <tr> <td>leicht lenkend</td> <td>-</td> <td>+</td> <td>++</td> </tr> <tr> <td>verschleißarm</td> <td>X</td> <td></td> <td></td> </tr> <tr> <td>stoßfest</td> <td>X</td> <td></td> <td></td> </tr> <tr> <td>bodenschonend</td> <td></td> <td>X</td> <td></td> </tr> <tr> <td>witterungsbeständig</td> <td></td> <td>X</td> <td></td> </tr> </table>	leicht lenkend	-	+	++	verschleißarm	X			stoßfest	X			bodenschonend		X		witterungsbeständig		X	
leicht lenkend	-	+	++																			
verschleißarm	X																					
stoßfest	X																					
bodenschonend		X																				
witterungsbeständig		X																				
<p>Polyurethan Felge Polyamid 6</p>																						

### Technische Details

<b>ORDERNO (Artikel-nummer)</b>	801 PT 150 AELK
<b>WDAB (Rad-Ø A x Breite B / mm)</b>	150x32
<b>LC (Tragkraft / kg)</b>	120
<b>H (Bauhöhe H / mm)</b>	195
<b>TP (Plattengröße / mm)</b>	90x70
<b>HS (Lochabstand / mm)</b>	70x50
<b>HD (Loch-Ø / mm)</b>	8.5
<b>SR (Schwenkradius / mm)</b>	134
<b>WB (Radlager)</b>	Kugellager