

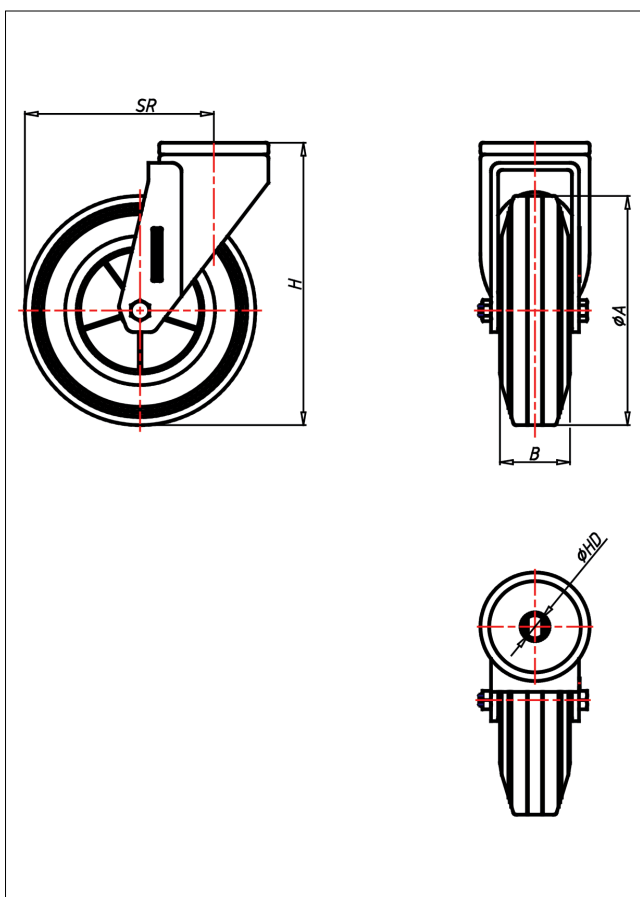

# CR-DGB/DG

## Lenkrolle



### CR-DG



LENKROLLE	LENKROLLE MIT TOTALFESTSTELLER																			
																				
<ul style="list-style-type: none"> <li>• spurfrei - bodenschonend</li> <li>• hoher Fahrkomfort</li> <li>• sehr lauffähig</li> <li>• geringer Rollwiderstand</li> <li>• abriebfest</li> </ul> ELASTIK-Vollgummi Felge Kunststoff → Seite 262	 zweifaches Kugellager - vernietet Stahlkugeln gehärtet Radachse verschraubt, verzinkt → Seite 62	AUSWAHLHILFE: <table border="0"> <tr> <td>○</td><td>+</td><td>+</td></tr> <tr> <td>leicht lenkend</td><td>X</td><td>○</td></tr> <tr> <td>verschleißarm</td><td>○</td><td>X</td></tr> <tr> <td>stoßfest</td><td>X</td><td>○</td></tr> <tr> <td>bodenschonend</td><td>○</td><td>X</td></tr> <tr> <td>witterungsbeständig</td><td>X</td><td>X</td></tr> </table>	○	+	+	leicht lenkend	X	○	verschleißarm	○	X	stoßfest	X	○	bodenschonend	○	X	witterungsbeständig	X	X
○	+	+																		
leicht lenkend	X	○																		
verschleißarm	○	X																		
stoßfest	X	○																		
bodenschonend	○	X																		
witterungsbeständig	X	X																		

### Technische Details

<b>ORDERNO (Artikel-nummer)</b>	CR 150 DG
<b>WDAB (Rad-Ø A x Breite B / mm)</b>	150x40
<b>LC (Tragkraft / kg)</b>	150
<b>H (Bauhöhe H / mm)</b>	181
<b>HD (Loch-Ø / mm)</b>	12.5
<b>SR (Schwenkradius / mm)</b>	126
<b>WB (Radlager)</b>	Nylon-Gleitlager