

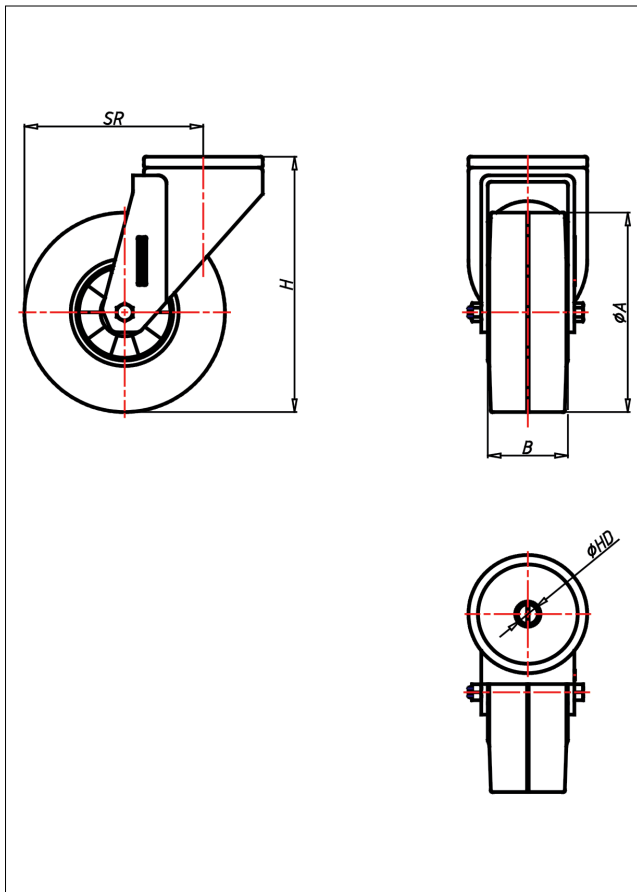

# CR/CRS- EK/EB/LEK/LEB Lenkrolle



## CR-E



LENKROLLE	LENKROLLE MIT TOTALFESTSTELLER																					
<ul style="list-style-type: none"> <li>• hoher Fahrkomfort</li> <li>• sehr laufruhig</li> <li>• geringer Rollwiderstand</li> <li>• abriebfest</li> <li>• spurfrei in grau</li> </ul>	 zweifaches Kugellager - vernietet Stahlkugeln gehärtet Radachse verschraubt, verzinkt → Seite 62	AUSWAHLHILFE: <table border="0"> <tr> <td>leicht lenkend</td> <td>+</td> <td>+</td> <td>+</td> </tr> <tr> <td>verschleißarm</td> <td>x</td> <td>x</td> <td>x</td> </tr> <tr> <td>stoßfest</td> <td>+</td> <td>+</td> <td>+</td> </tr> <tr> <td>bodenschonend</td> <td>+</td> <td>+</td> <td>+</td> </tr> <tr> <td>witterungsbeständig</td> <td>x</td> <td>x</td> <td>x</td> </tr> </table>	leicht lenkend	+	+	+	verschleißarm	x	x	x	stoßfest	+	+	+	bodenschonend	+	+	+	witterungsbeständig	x	x	x
leicht lenkend	+	+	+																			
verschleißarm	x	x	x																			
stoßfest	+	+	+																			
bodenschonend	+	+	+																			
witterungsbeständig	x	x	x																			
ELASTIK-Vollgummi Felge Spritzguss- Aluminiumlegierung → Seite 259																						

## Technische Details

<b>ORDERNO (Artikel-nummer)</b>	CRS 160 EB
<b>WDAB (Rad-Ø A x Breite B / mm)</b>	160x50
<b>LC (Tragkraft / kg)</b>	300
<b>H (Bauhöhe H / mm)</b>	196
<b>HD (Loch-Ø / mm)</b>	12.5
<b>SR (Schwenkradius / mm)</b>	136
<b>WB (Radlager)</b>	Rollenlager