

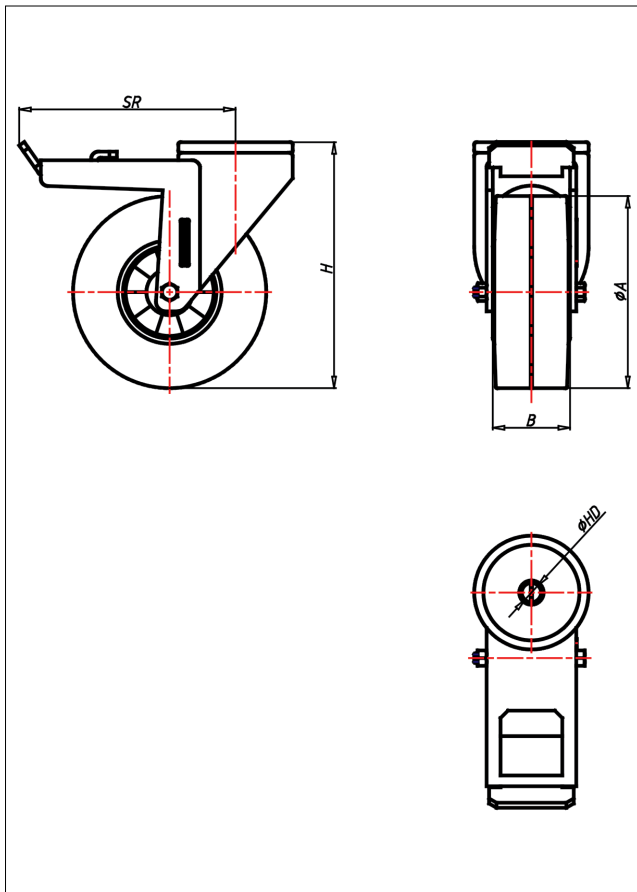

# CRT/CRST- EK/EB/LEK/LEB

Lenkrolle mit Totalfeststeller



## CR-E



LENKROLLE	LENKROLLE MIT TOTALFESTSTELLER	
<ul style="list-style-type: none"> <li>• hoher Fahrkomfort</li> <li>• sehr laufruhig</li> <li>• geringer Rollwiderstand</li> <li>• abriebfest</li> <li>• spurfrei in grau</li> </ul>	<ul style="list-style-type: none"> <li>• zweifaches Kugellager - vernietet</li> <li>• Stahlkugeln gehärtet</li> <li>• Radachse verschraubt, verzinkt</li> </ul>	<p>AUSWAHLHILFE:</p> <ul style="list-style-type: none"> <li>leicht lenkend <input type="checkbox"/></li> <li>verschleißarm <input type="checkbox"/></li> <li>stoßfest <input type="checkbox"/></li> <li>bodenschonend <input type="checkbox"/></li> <li>witterungsbeständig <input type="checkbox"/></li> </ul>
ELASTIK-Vollgummi Felge Spritzguss- Aluminiumlegierung → Seite 259	 → Seite 52	

## Technische Details

<b>ORDERNO (Artikel-nummer)</b>	CRST 160 EB
<b>WDAB (Rad-Ø A x Breite B / mm)</b>	160x50
<b>LC (Tragkraft / kg)</b>	300
<b>H (Bauhöhe H / mm)</b>	196
<b>HD (Loch-Ø / mm)</b>	12.5
<b>SR (Schwenkradius / mm)</b>	168
<b>WB (Radlager)</b>	Rollenlager