

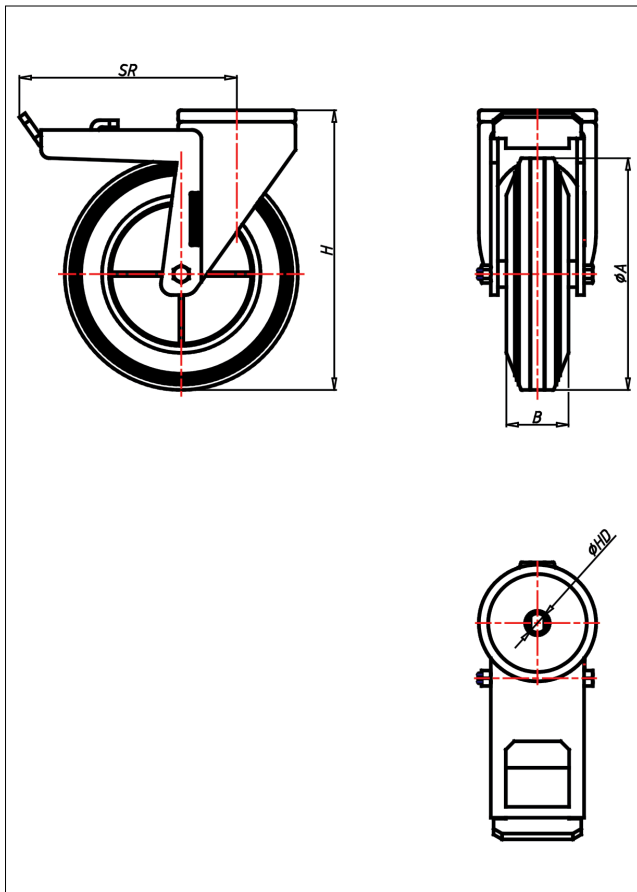

# CRT-CK/CB

## Lenkrolle mit Totalfeststeller



CR-C



LENKROLLE	LENKROLLE MIT TOTALFESTSTELLER																			
<ul style="list-style-type: none"> <li>• geräuscharmer Lauf</li> <li>• großer Fahrkomfort</li> <li>• beständig gegen verdünnte Säuren</li> </ul> Vollgummi schwarz Felge Stahlblech verzinkt → Seite 205	<ul style="list-style-type: none"> <li>zweifaches Kugellager - vernietet</li> <li>Stahlkugeln gehärtet</li> <li>Radachse verschraubt, verzinkt</li> </ul> → Seite 62	AUSWAHLHILFE: <table border="0"> <tr> <td>○</td><td>+</td><td>+</td></tr> <tr> <td>leicht lenkend</td><td>X</td><td>X</td></tr> <tr> <td>verschleißarm</td><td>X</td><td>X</td></tr> <tr> <td>stoßfest</td><td>X</td><td>X</td></tr> <tr> <td>bodenschonend</td><td>X</td><td>X</td></tr> <tr> <td>witterungsbeständig</td><td>X</td><td>X</td></tr> </table>	○	+	+	leicht lenkend	X	X	verschleißarm	X	X	stoßfest	X	X	bodenschonend	X	X	witterungsbeständig	X	X
○	+	+																		
leicht lenkend	X	X																		
verschleißarm	X	X																		
stoßfest	X	X																		
bodenschonend	X	X																		
witterungsbeständig	X	X																		

### Technische Details

ORDERNO (Artikel-nummer)	CRT 125 CK
WDAB (Rad-Ø A x Breite B / mm)	125x38
LC (Tragkraft / kg)	120
H (Bauhöhe H / mm)	154
HD (Loch-Ø / mm)	12.5
SR (Schwenkradius / mm)	108
WB (Radlager)	Kugellager