

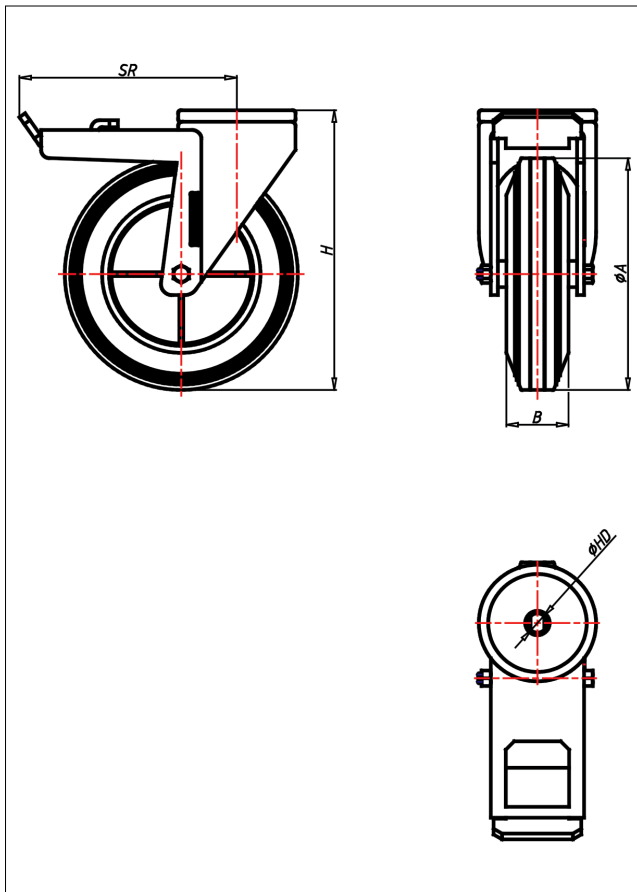

CRT-CK/CB

Lenkrolle mit Totalfeststeller



CR-C



LENKROLLE	LENKROLLE MIT TOTALFESTSTELLER																					
<ul style="list-style-type: none"> • geräuscharmer Lauf • großer Fahrkomfort • beständig gegen verdünnte Säuren Vollgummi schwarz Felge Stahlblech verzinkt → Seite 205	<ul style="list-style-type: none"> • zweifaches Kugellager - vernietet • Stahlkugeln gehärtet • Radachse verschraubt, verzinkt → Seite 62	AUSWAHLHILFE: <table border="1"> <tr> <td>leicht lenkend</td> <td>X</td> <td>+</td> <td>+</td> </tr> <tr> <td>verschleißarm</td> <td>X</td> <td>+</td> <td>+</td> </tr> <tr> <td>stoßfest</td> <td>X</td> <td>+</td> <td>+</td> </tr> <tr> <td>bodenschonend</td> <td>X</td> <td>+</td> <td>+</td> </tr> <tr> <td>witterungsbeständig</td> <td>X</td> <td>+</td> <td>+</td> </tr> </table>	leicht lenkend	X	+	+	verschleißarm	X	+	+	stoßfest	X	+	+	bodenschonend	X	+	+	witterungsbeständig	X	+	+
leicht lenkend	X	+	+																			
verschleißarm	X	+	+																			
stoßfest	X	+	+																			
bodenschonend	X	+	+																			
witterungsbeständig	X	+	+																			

Technische Details

ORDERNO (Artikel-nummer)	CRT 180 CK
WDAB (Rad-Ø A x Breite B / mm)	180x45
LC (Tragkraft / kg)	200
H (Bauhöhe H / mm)	218
HD (Loch-Ø / mm)	12.5
SR (Schwenkradius / mm)	168
WB (Radlager)	Kugellager