

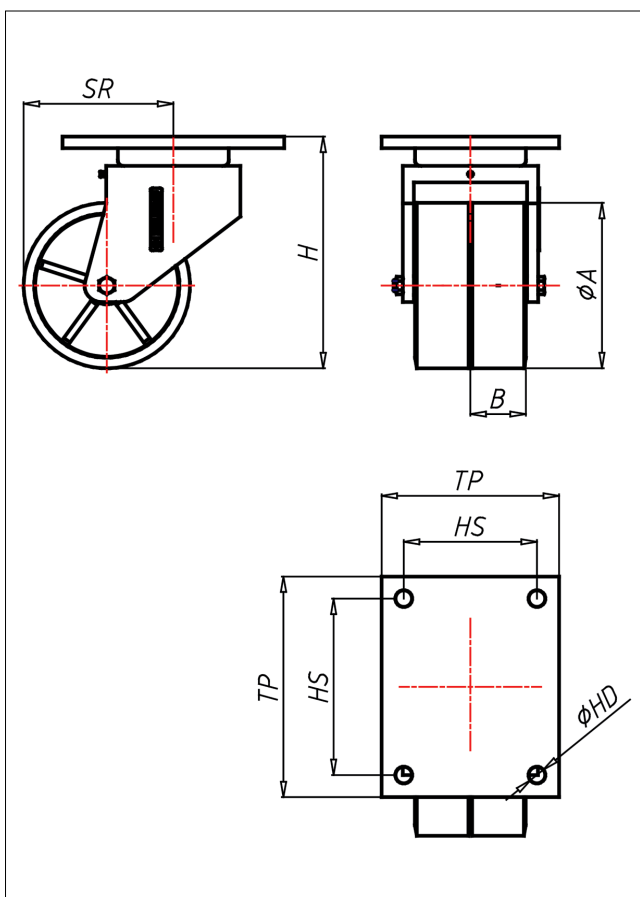

EDD/ES-ZK/ZZK

Lenkrolle

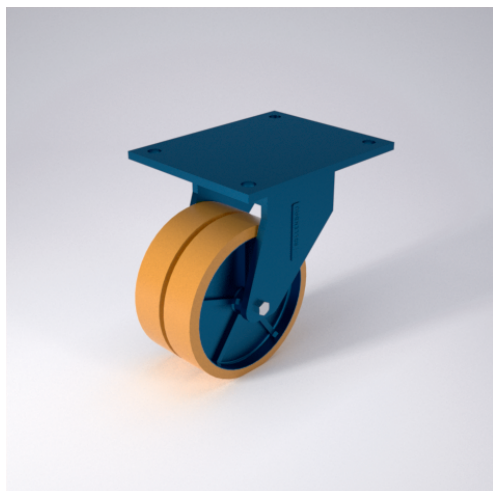

EDD-Z



LENKROLLE	Feststeller TLCH Seite 42	BOCKROLLE
<ul style="list-style-type: none"> geräuscharmer Lauf geringer Rollwiderstand abrieb- und reißfest hohe Stoßfestigkeit sehr beständig gegen viele aggressive Medien <p>Guss-Polyurethan Felge Gusseisen lackiert → Seite 245</p>	<p>Schrägrollen- und Axialkugellager, staubgeschützt, sehr starker Zentralbolzen, Mütter gesichert, Schmiempel Ausführung – lackiert → Seite 25</p>	<p>AUSWAHLHILFE:</p> <ul style="list-style-type: none"> leicht lenkend verschleißarm stoßfest bodenschonend witterungsbeständig

Technische Details

ORDERNO (Artikel-nummer)	EDD 125 ZZK
WDAB (Rad-Ø A x Breite B / mm)	125x40+40
LC (Tragkraft / kg)	800
H (Bauhöhe H / mm)	197
TP (Plattengröße / mm)	200x160
HS (Lochabstand / mm)	160x120
HD (Loch-Ø / mm)	15
SR (Schwenkradius / mm)	122.5
WB (Radlager)	Kugellager