

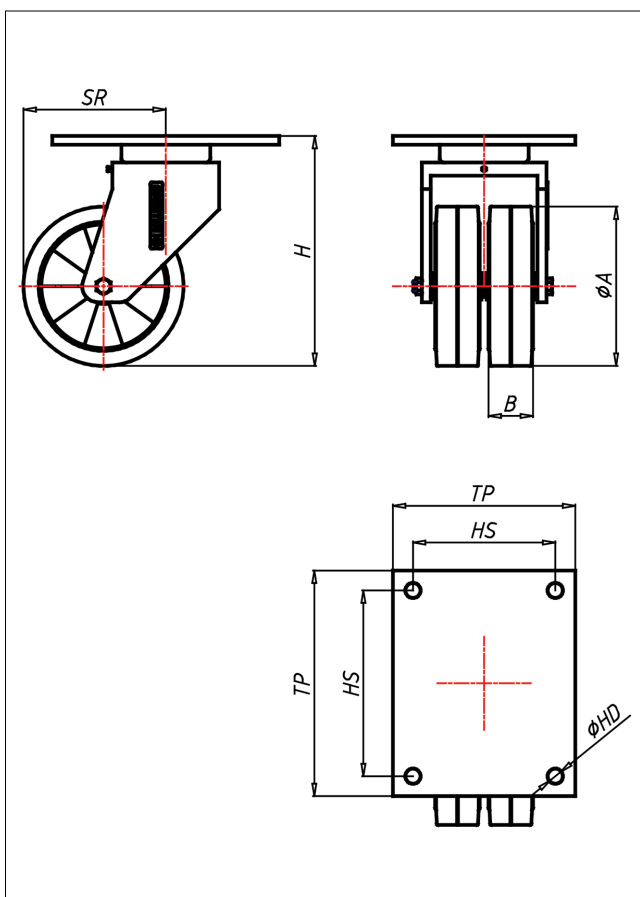

EDD-EEK/LEEK

Lenkrolle



EDD-E



| LENKROLLE | Festssteller TLCH Seite 42 | BOCKROLLE | | | | | | | | | | | | | | | | | | | | | | | | | |
|--|---|--|-----------------------|-----------------------|-----------------------|-----------------------|-----------------------|---------------|-----------------------|----------------------------------|-----------------------|-----------------------|----------|-----------------------|----------------------------------|-----------------------|-----------------------|---------------|-----------------------|----------------------------------|-----------------------|-----------------------|---------------------|-----------------------|----------------------------------|-----------------------|-----------------------|
| | | | | | | | | | | | | | | | | | | | | | | | | | | | |
| <ul style="list-style-type: none"> • hoher Fahrkomfort • sehr laufruhig • geringer Rollwiderstand • abriebfest • spurfrei in grau | <p>Schrägrollen- und Axialkugellager, staubgeschützt, sehr starker Zentralbolzen, Mutter gesichert, Schmiempipel Ausführung – lackiert → Seite 26</p> | <p>AUSWAHLHILFE:</p> <table border="0"> <tr> <td>leicht lenkend</td> <td><input type="radio"/></td> <td><input type="radio"/></td> <td><input type="radio"/></td> <td><input type="radio"/></td> </tr> <tr> <td>verschleißarm</td> <td><input type="radio"/></td> <td><input checked="" type="radio"/></td> <td><input type="radio"/></td> <td><input type="radio"/></td> </tr> <tr> <td>stoßfest</td> <td><input type="radio"/></td> <td><input checked="" type="radio"/></td> <td><input type="radio"/></td> <td><input type="radio"/></td> </tr> <tr> <td>bodenschonend</td> <td><input type="radio"/></td> <td><input checked="" type="radio"/></td> <td><input type="radio"/></td> <td><input type="radio"/></td> </tr> <tr> <td>witterungsbeständig</td> <td><input type="radio"/></td> <td><input checked="" type="radio"/></td> <td><input type="radio"/></td> <td><input type="radio"/></td> </tr> </table> | leicht lenkend | <input type="radio"/> | <input type="radio"/> | <input type="radio"/> | <input type="radio"/> | verschleißarm | <input type="radio"/> | <input checked="" type="radio"/> | <input type="radio"/> | <input type="radio"/> | stoßfest | <input type="radio"/> | <input checked="" type="radio"/> | <input type="radio"/> | <input type="radio"/> | bodenschonend | <input type="radio"/> | <input checked="" type="radio"/> | <input type="radio"/> | <input type="radio"/> | witterungsbeständig | <input type="radio"/> | <input checked="" type="radio"/> | <input type="radio"/> | <input type="radio"/> |
| leicht lenkend | <input type="radio"/> | <input type="radio"/> | <input type="radio"/> | <input type="radio"/> | | | | | | | | | | | | | | | | | | | | | | | |
| verschleißarm | <input type="radio"/> | <input checked="" type="radio"/> | <input type="radio"/> | <input type="radio"/> | | | | | | | | | | | | | | | | | | | | | | | |
| stoßfest | <input type="radio"/> | <input checked="" type="radio"/> | <input type="radio"/> | <input type="radio"/> | | | | | | | | | | | | | | | | | | | | | | | |
| bodenschonend | <input type="radio"/> | <input checked="" type="radio"/> | <input type="radio"/> | <input type="radio"/> | | | | | | | | | | | | | | | | | | | | | | | |
| witterungsbeständig | <input type="radio"/> | <input checked="" type="radio"/> | <input type="radio"/> | <input type="radio"/> | | | | | | | | | | | | | | | | | | | | | | | |
| <p>ELASTIK-Vollgummi Felge Spritzguss- Aluminiumlegierung → Seite 259</p> | | | | | | | | | | | | | | | | | | | | | | | | | | | |

Technische Details

| | |
|---------------------------------------|-------------|
| ORDERNO (Artikel-nummer) | EDD 300 EEK |
| WDAB (Rad-Ø A x Breite B / mm) | 300x60+60 |
| LC (Tragkraft / kg) | 1400 |
| H (Bauhöhe H / mm) | 380 |
| TP (Plattengröße / mm) | 255x205 |
| HS (Lochabstand / mm) | 210x160 |
| HD (Loch-Ø / mm) | 17 |
| SR (Schwenkradius / mm) | 240 |
| WB (Radlager) | Kugellager |