

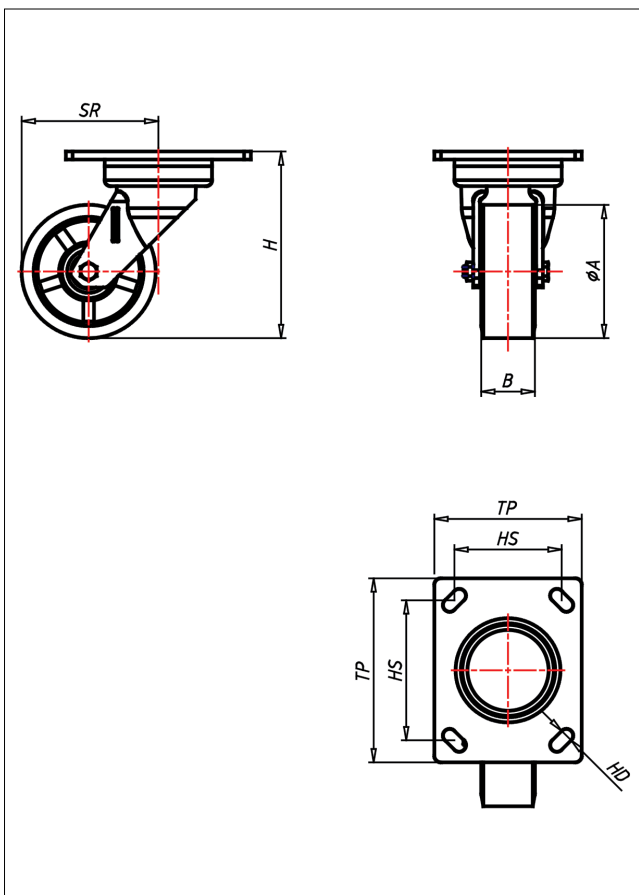

GT-ZK/SUB/LZK

Lenkrolle

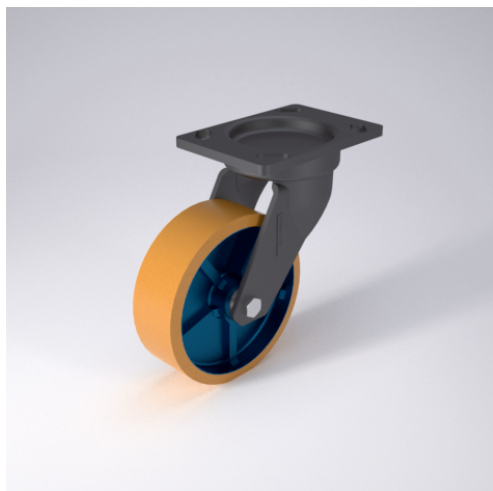

GT-SU



LENKROLLE	RADFESTSTELLER	BOCKROLLE																				
 <ul style="list-style-type: none"> • geräuscharmer Lauf • geringer Rollwiderstand • abrieb- und reißfest • hohe Stoßfestigkeit • sehr beständig gegen viele aggressive Medien <p>Guss-Polyurethan Felge Gusseisen lackiert → Seite 247</p> 	 <p>Schwerlastlenkgehäuse ohne Mittelbolzen mit gehärtetem Drehkranz und gehärteten Stahlkugeln, geschmiedet und getempert → Seite 42</p>	 <p>AUSWAHLHILFE:</p> <table border="0"> <tr> <td>leicht lenkend</td> <td>-</td> <td>+</td> <td>++</td> </tr> <tr> <td>verschleißarm</td> <td>x</td> <td></td> <td></td> </tr> <tr> <td>stoßfest</td> <td></td> <td>x</td> <td></td> </tr> <tr> <td>bodenschonend</td> <td></td> <td></td> <td>x</td> </tr> <tr> <td>witterungsbeständig</td> <td>x</td> <td></td> <td></td> </tr> </table>	leicht lenkend	-	+	++	verschleißarm	x			stoßfest		x		bodenschonend			x	witterungsbeständig	x		
leicht lenkend	-	+	++																			
verschleißarm	x																					
stoßfest		x																				
bodenschonend			x																			
witterungsbeständig	x																					

Technische Details

ORDERNO (Artikel-nummer)	GT 150 ZK
WDAB (Rad-Ø A x Breite B / mm)	150x40
LC (Tragkraft / kg)	500
H (Bauhöhe H / mm)	200
TP (Plattengröße / mm)	150x105
HS (Lochabstand / mm)	105x80
HD (Loch-Ø / mm)	13
SR (Schwenkradius / mm)	148
WB (Radlager)	Kugellager