

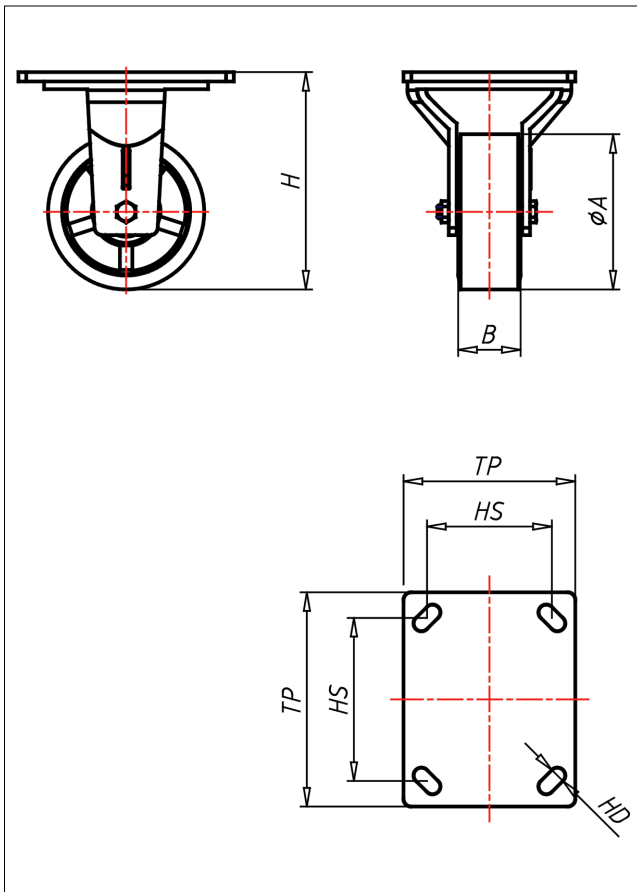

GTF-ZK/SUB/LZK

Bockrolle

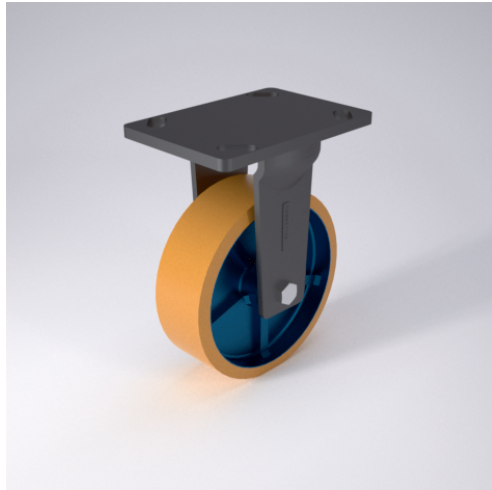

GT-SU



LENKROLLE	RADFESTSTELLER	BOCKROLLE																		
<ul style="list-style-type: none"> geräuscharmer Lauf geringer Rollwiderstand abrieb- und reißfest hohe Stoßfestigkeit sehr beständig gegen viele aggressive Medien <p>Guss-Polyurethan Felge Gusseisen lackiert → Seite 247</p>	<p>Schwerlastlenkgehäuse ohne Mittelbolzen mit gehärtetem Drehkranz und gehärteten Stahlkugeln, geschmiedet und getempert</p> <p>→ Seite 42</p>	<p>AUSWAHLHILFE:</p> <table border="0"> <tr> <td>-</td> <td>+</td> <td>++</td> </tr> <tr> <td>leicht lenkend</td> <td>X</td> <td>X</td> </tr> <tr> <td>verschleißarm</td> <td>X</td> <td>X</td> </tr> <tr> <td>stoßfest</td> <td>X</td> <td>X</td> </tr> <tr> <td>bodenschonend</td> <td>X</td> <td>X</td> </tr> <tr> <td>witterungsbeständig</td> <td>X</td> <td>X</td> </tr> </table>	-	+	++	leicht lenkend	X	X	verschleißarm	X	X	stoßfest	X	X	bodenschonend	X	X	witterungsbeständig	X	X
-	+	++																		
leicht lenkend	X	X																		
verschleißarm	X	X																		
stoßfest	X	X																		
bodenschonend	X	X																		
witterungsbeständig	X	X																		

Technische Details

ORDERNO (Artikel-nummer)	GTF 101 ZK
WDAB (Rad-Ø A x Breite B / mm)	100x40
LC (Tragkraft / kg)	350
H (Bauhöhe H / mm)	140
TP (Plattengröße / mm)	138x110
HS (Lochabstand / mm)	105x80
HD (Loch-Ø / mm)	10
WB (Radlager)	Kugellager