

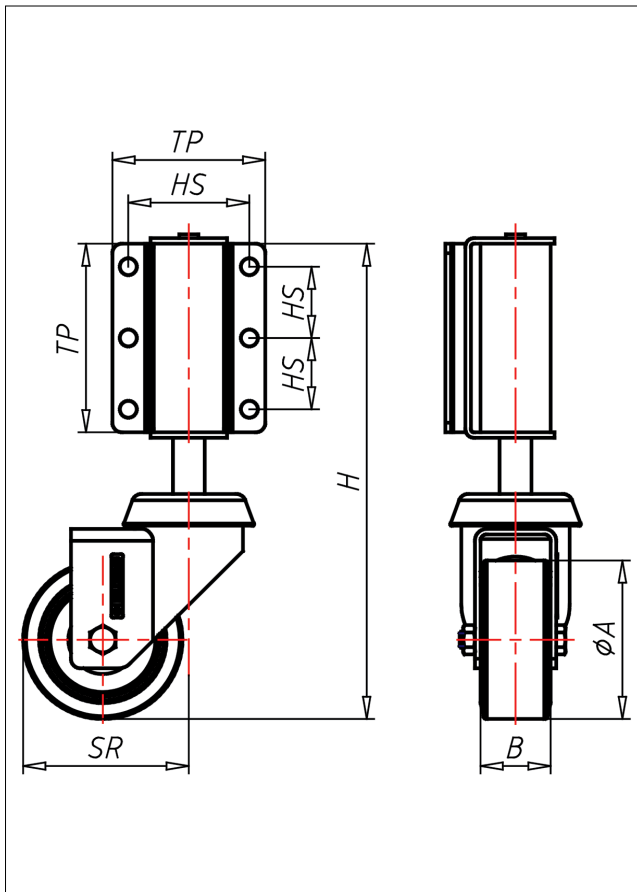

LR315-GK/G/GL

Lenkrolle



LR-G Gefederte Rollen



<p>LENKROLLE</p>  <p>Federnde Leiterrolle MIT BELASTUNGSABHÄNGIGER FESTSTELLWIRKUNG Die Anschraubplatte ist leicht demontierbar und kann um 90 Grad geschwenkt werden. Gesamtfederdruck 17 kg, Federweg maximal 22 mm</p>																				
<p>Thermoplastisches Elastomer Felge Polyamid 6 → Seite 268</p> 	<p>ANDERE RÄDER AUF ANFRAGE</p> 	<p>AUSWAHLHILFE:</p> <table border="0"> <tr> <td>-</td> <td>+</td> <td>++</td> </tr> <tr> <td>leicht lenkend</td> <td>X</td> <td>X</td> </tr> <tr> <td>verschleißarm</td> <td>X</td> <td>X</td> </tr> <tr> <td>stoßfest</td> <td>X</td> <td>X</td> </tr> <tr> <td>bodenschonend</td> <td>X</td> <td>X</td> </tr> <tr> <td>witterungsbeständig</td> <td>X</td> <td>X</td> </tr> </table>	-	+	++	leicht lenkend	X	X	verschleißarm	X	X	stoßfest	X	X	bodenschonend	X	X	witterungsbeständig	X	X
-	+	++																		
leicht lenkend	X	X																		
verschleißarm	X	X																		
stoßfest	X	X																		
bodenschonend	X	X																		
witterungsbeständig	X	X																		

Technische Details

ORDERNO (Artikel-nummer)	LR315 50 GK
WDAB (Rad-Ø A x Breite B / mm)	50x22
LC (Tragkraft / kg)	50
H (Bauhöhe H / mm)	150
TP (Plattengröße / mm)	59.5x48
HS (Lochabstand / mm)	38x22.5
HD (Loch-Ø / mm)	5.3
SR (Schwenkradius / mm)	52
WB (Radlager)	Kugellager