

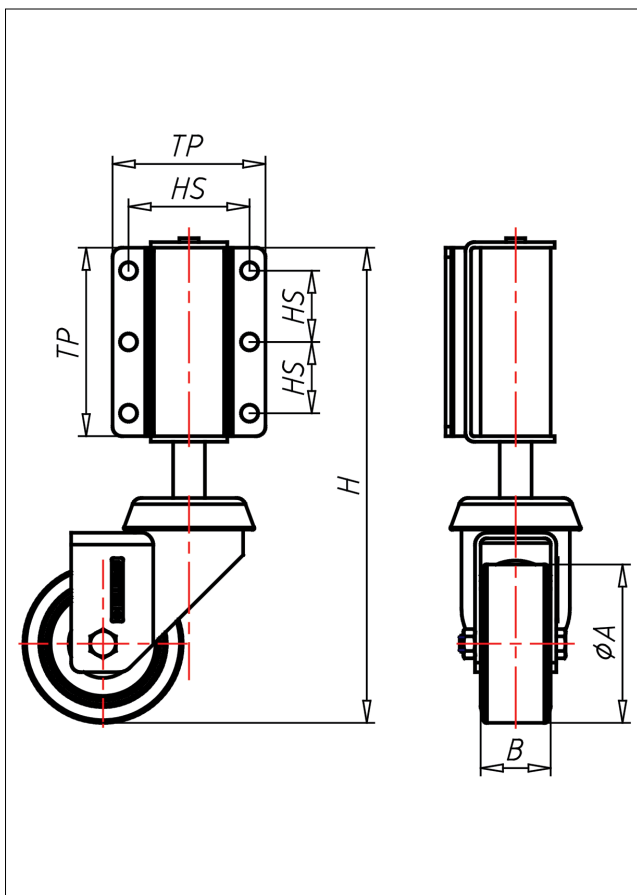

# LR670-GK/G/GL

## Bockrolle



### LR-G Gefederte Rollen



LENKROLLE																				
	<p>Federnde Leiterrolle MIT BELASTUNGSABHÄNGIGER FESTSTELLWIRKUNG</p> <p>Die Anschraubplatte ist leicht demontierbar und kann um 90 Grad geschwenkt werden.</p> <p>Gesamtfederdruck 17 kg, Federweg maximal 22 mm</p>																			
<p>Thermoplastisches Elastomer</p> <p>Felge Polyamid 6</p> <p>→ Seite 268</p>	<p>ANDERE RÄDER AUF ANFRAGE</p>	<p>AUSWAHLHILFE:</p> <table border="0"> <tr> <td>-</td> <td>+</td> <td>++</td> </tr> <tr> <td>leicht lenkend</td> <td><input checked="" type="checkbox"/></td> <td><input checked="" type="checkbox"/></td> </tr> <tr> <td>verschleißarm</td> <td><input checked="" type="checkbox"/></td> <td><input checked="" type="checkbox"/></td> </tr> <tr> <td>stoßfest</td> <td><input checked="" type="checkbox"/></td> <td><input checked="" type="checkbox"/></td> </tr> <tr> <td>bodenschonend</td> <td><input checked="" type="checkbox"/></td> <td><input checked="" type="checkbox"/></td> </tr> <tr> <td>witterungsbeständig</td> <td><input checked="" type="checkbox"/></td> <td><input checked="" type="checkbox"/></td> </tr> </table>	-	+	++	leicht lenkend	<input checked="" type="checkbox"/>	<input checked="" type="checkbox"/>	verschleißarm	<input checked="" type="checkbox"/>	<input checked="" type="checkbox"/>	stoßfest	<input checked="" type="checkbox"/>	<input checked="" type="checkbox"/>	bodenschonend	<input checked="" type="checkbox"/>	<input checked="" type="checkbox"/>	witterungsbeständig	<input checked="" type="checkbox"/>	<input checked="" type="checkbox"/>
-	+	++																		
leicht lenkend	<input checked="" type="checkbox"/>	<input checked="" type="checkbox"/>																		
verschleißarm	<input checked="" type="checkbox"/>	<input checked="" type="checkbox"/>																		
stoßfest	<input checked="" type="checkbox"/>	<input checked="" type="checkbox"/>																		
bodenschonend	<input checked="" type="checkbox"/>	<input checked="" type="checkbox"/>																		
witterungsbeständig	<input checked="" type="checkbox"/>	<input checked="" type="checkbox"/>																		

### Technische Details

<b>ORDERNO (Artikel-nummer)</b>	LR670 50 G
<b>WDAB (Rad-Ø A x Breite B / mm)</b>	50x19
<b>LC (Tragkraft / kg)</b>	50
<b>H (Bauhöhe H / mm)</b>	150
<b>TP (Plattengröße / mm)</b>	59.5x48
<b>HS (Lochabstand / mm)</b>	38x22.5
<b>HD (Loch-Ø / mm)</b>	5.3
<b>WB (Radlager)</b>	Gleitlager