

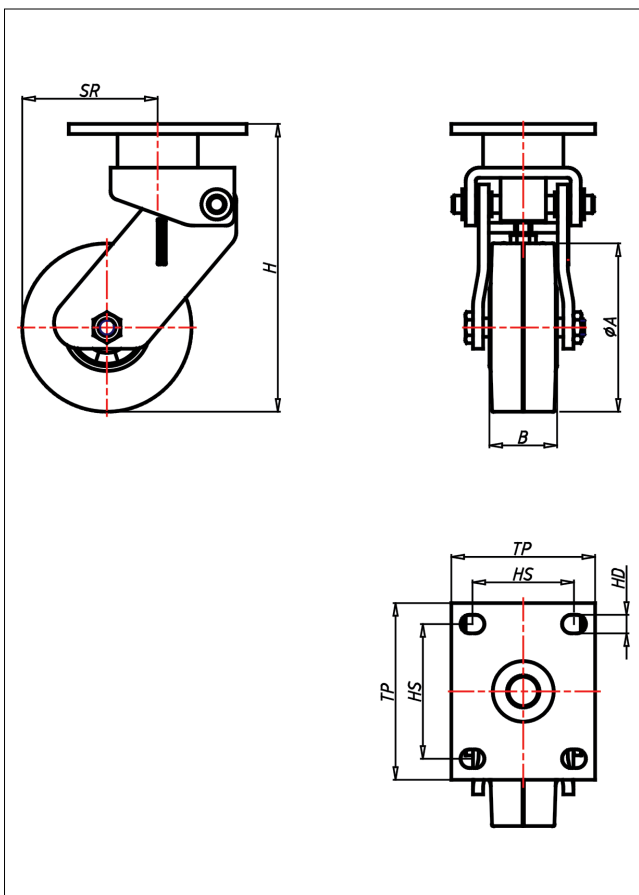

MFA/MFB/MFC- EK/EB/LEK/LEB

Lenkrolle



MFA-E



LENKROLLE	BOCKROLLE	
<ul style="list-style-type: none"> • hoher Fahrkomfort • sehr laufruhig • geringer Rollwiderstand • abriebfest • spurfrei in grau 	<ul style="list-style-type: none"> • zweifaches Kugellager • Polyurethan-Federelement • Schwinghebel auf Bronzebuchsen, schwarz lackiert 	<p>AUSWAHLHILFE:</p> <ul style="list-style-type: none"> leicht lenkend <input type="checkbox"/> <input checked="" type="checkbox"/> verschleißarm <input type="checkbox"/> <input checked="" type="checkbox"/> stoßfest <input type="checkbox"/> <input checked="" type="checkbox"/> bodenschonend <input type="checkbox"/> <input checked="" type="checkbox"/> witterungsbeständig <input type="checkbox"/> <input checked="" type="checkbox"/>
ELASTIK-Vollgummi Felge Spritzguss- Aluminiumlegierung → Seite 259		
	→ Seite 62	

Technische Details

ORDERNO (Artikel-nummer)	MFA 100 EK
WDAB (Rad-Ø A x Breite B / mm)	100x40
LC (Tragkraft / kg)	130
PF (Vorspannkraft / daN)	40
MST (Max. Federweg / mm)	25
H (Bauhöhe H / mm)	171
TP (Plattengröße / mm)	105x85
HS (Lochabstand / mm)	80x60
HD (Loch-Ø / mm)	11
SR (Schwenkradius / mm)	80
WB (Radlager)	Kugellager