

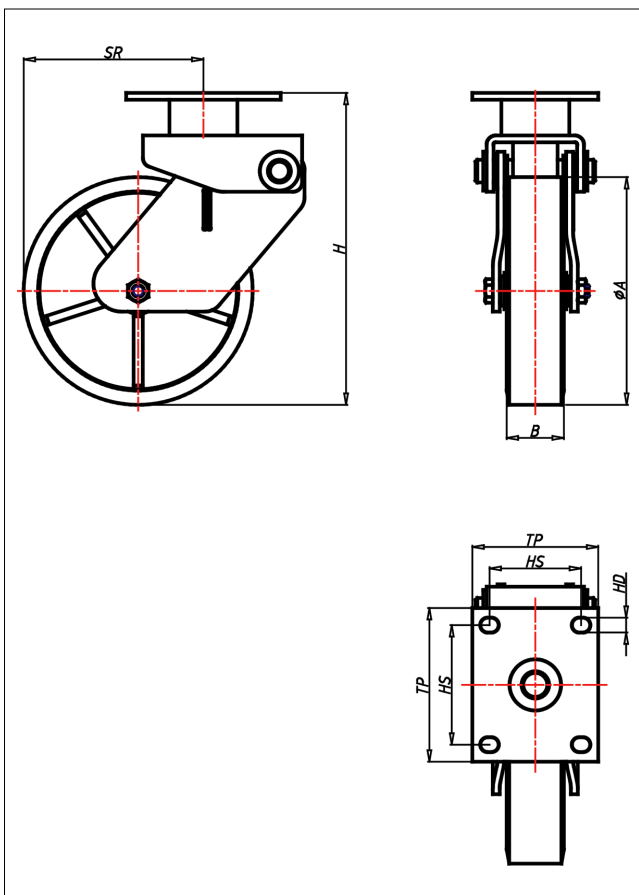

# MFA/MFB/MFC-ZK

## Lenkrolle



### MFA-Z



LENKROLLE	BOCKROLLE	
<ul style="list-style-type: none"> <li>geräuscharmer Lauf</li> <li>geringer Rollwiderstand</li> <li>abrieb- und reißfest</li> <li>hohe Stoßfestigkeit</li> <li>sehr beständig gegen viele aggressive Medien</li> </ul>	<ul style="list-style-type: none"> <li>zweifaches Kugellager, Polyurethan-Federelement</li> <li>Schwinghebel auf Bronzebuchsen, schwarz lackiert</li> </ul>	<b>AUSWAHLHILFE:</b> <ul style="list-style-type: none"> <li>leicht lenkend <input checked="" type="checkbox"/></li> <li>verschleißarm <input checked="" type="checkbox"/></li> <li>stoßfest <input checked="" type="checkbox"/></li> <li>bodenschonend <input checked="" type="checkbox"/></li> <li>witterungsbeständig <input checked="" type="checkbox"/></li> </ul>
Guss-Polyurethan Felge Gusseisen lackiert → Seite 245	→ Seite 62	

### Technische Details

<b>ORDERNO (Artikel-nummer)</b>	MFA 101 ZK
<b>WDAB (Rad-Ø A x Breite B / mm)</b>	100x40
<b>LC (Tragkraft / kg)</b>	130
<b>PF (Vorspannkraft / daN)</b>	40
<b>MST (Max. Federweg / mm)</b>	25
<b>H (Bauhöhe H / mm)</b>	171
<b>TP (Plattengröße / mm)</b>	105x85
<b>HS (Lochabstand / mm)</b>	80x60
<b>HD (Loch-Ø / mm)</b>	11
<b>SR (Schwenkradius / mm)</b>	80
<b>WB (Radlager)</b>	Kugellager