

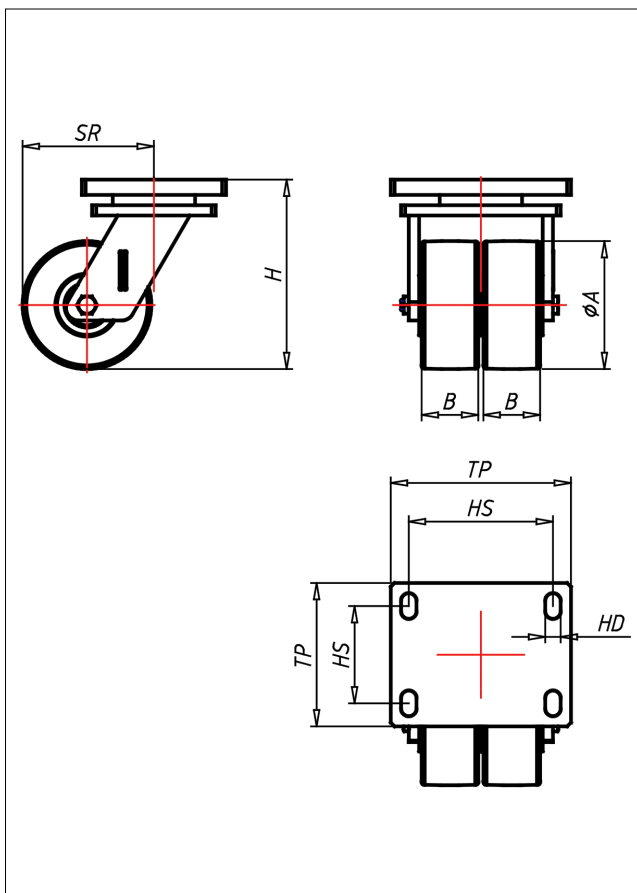

SMM/SMMS-PEK

Lenkrolle

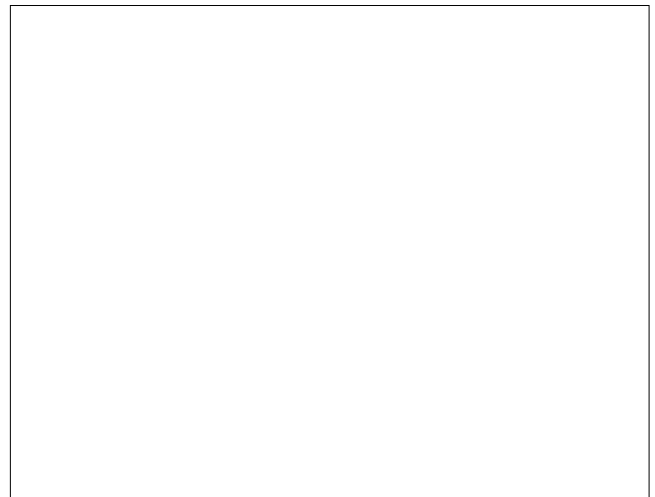

SMM-PE



LENKROLLE	LENKROLLE MIT TOTALFESTSTELLER	BOCKROLLE
<ul style="list-style-type: none"> • für extra schwere Lasten • leichter Lauf auf glatten Böden • stoß- und schlagfest • hohe Abriebfestigkeit • sehr beständig gegen viele aggressive Medien Guss-Polyamid 6 - 1. Wahl → Seite 271	 Schrägrollen- und Axialkugellager, staubgeschützt, sehr starker Zentralbolzen, Schmiernippel Ausführung - lackiert → Seite 26	AUSWAHLHILFE: <ul style="list-style-type: none"> leicht lenkend <input type="checkbox"/> verschleißarm <input type="checkbox"/> stoßfest <input type="checkbox"/> bodenschonend <input type="checkbox"/> witterungsbeständig <input type="checkbox"/>

Technische Details

ORDERNO (Artikel-nummer)	SMM 150 PEK
WDAB (Rad-Ø A x Breite B / mm)	150x40+40
LC (Tragkraft / kg)	2000
H (Bauhöhe H / mm)	220
TP (Plattengröße / mm)	140x110
HS (Lochabstand / mm)	105x75
HD (Loch-Ø / mm)	11
SR (Schwenkradius / mm)	140
WB (Radlager)	Kugellager