

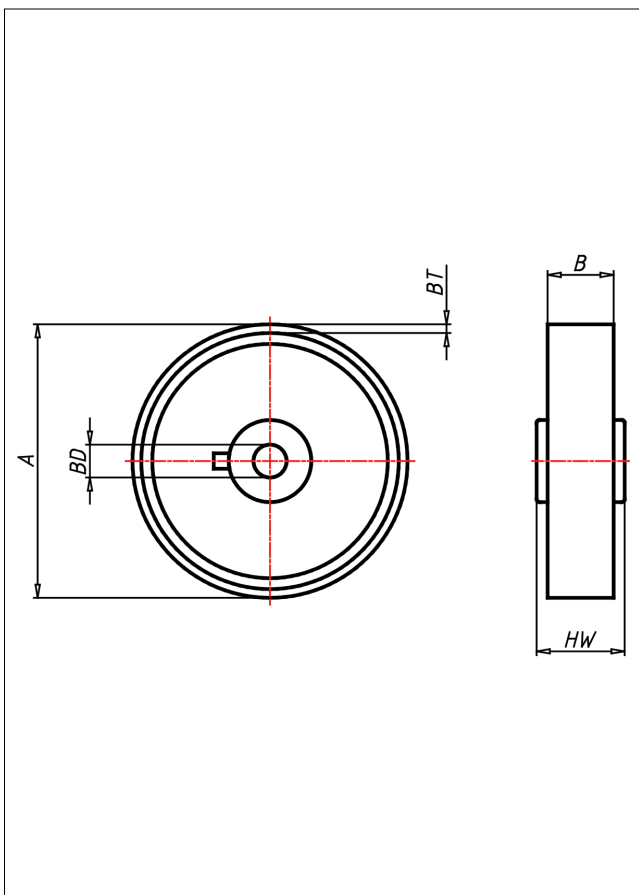

# AL Rad

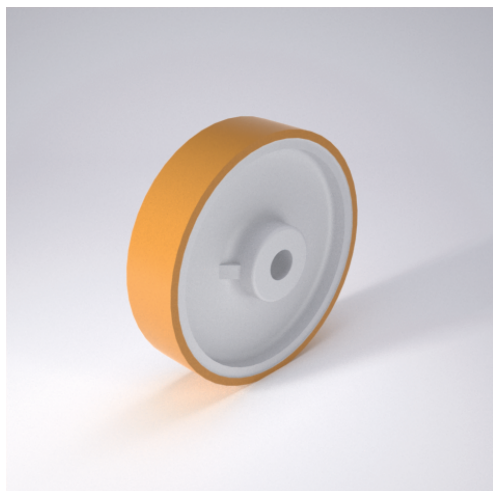

AL



Radkörper aus Polyamid 6 - 1. Wahl  
Laufbelag aus Spritzguss-Polyurethan,  
58±3 Shore D

- geringer Rollwiderstand
- abrieb- und reifest
- leichte Reinigung
- sehr beständig gegen viele aggressive Medien

## Technische Details

<b>ORDERNO (Artikel-nummer)</b>	125 AL-15
<b>WDAB (Rad-Ø A x Breite B / mm)</b>	125x30
<b>LC (Tragkraft / kg)</b>	230
<b>BT (Reifenstärke / mm)</b>	4
<b>HW (Nabenslänge / mm)</b>	40
<b>FL (Einbaulänge / mm)</b>	40
<b>WB (Radlager)</b>	Polyamid-Gleitlager
<b>BD (Bohrungsdurchmesser / mm)</b>	15