

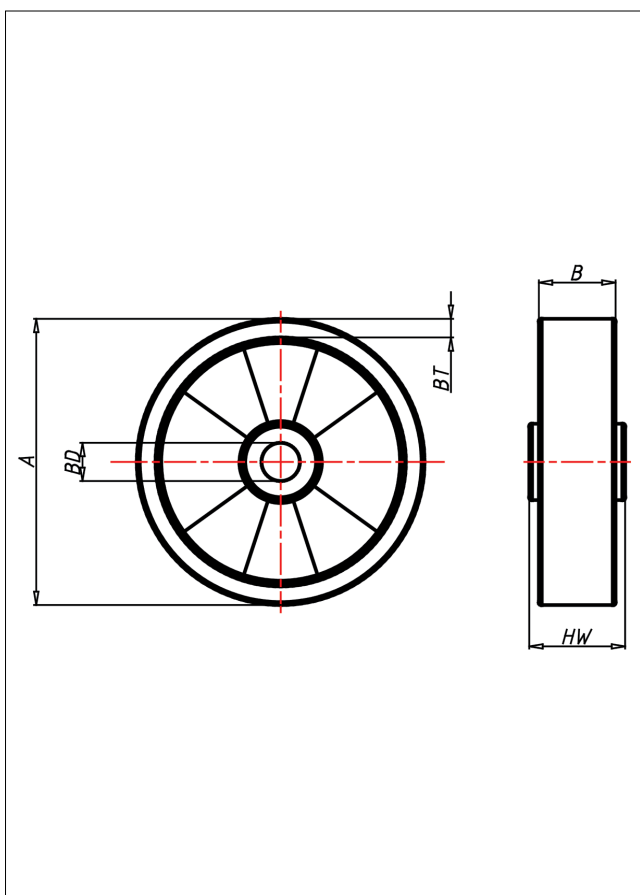

**TL**  
Rad

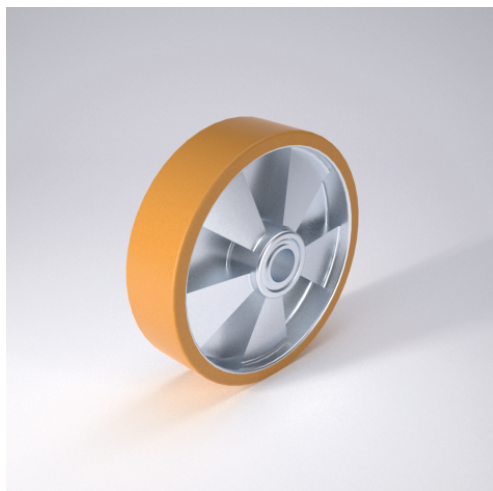

TL



Radkörper aus Spritzguss-Aluminium-Legierung  
Laufbelag aus Guss-Polyurethan 95E3 Shore A

- geräuscharmer Lauf
- geringer Rollwiderstand
- abrieb- und reißfest
- hohe Stoßfestigkeit
- sehr beständig gegen viele aggressive Medien

### Technische Details

<b>ORDERNO (Artikel-nummer)</b>	125 TLB 15
<b>WDAB (Rad-Ø A x Breite B / mm)</b>	125x30
<b>LC (Tragkraft / kg)</b>	250
<b>BT (Reifenstärke / mm)</b>	7.5
<b>HW (Nabellänge / mm)</b>	40
<b>FL (Einbaulänge / mm)</b>	40
<b>WB (Radlager)</b>	Rollenlager
<b>BD (Bohrungsdurchmesser / mm)</b>	15