

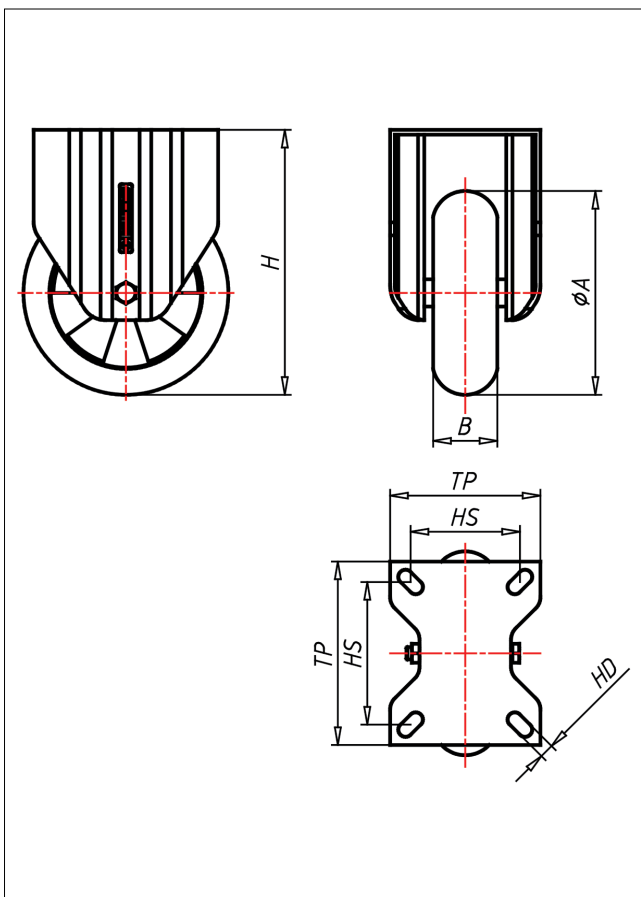

CDF-EGBAK

Bockrolle

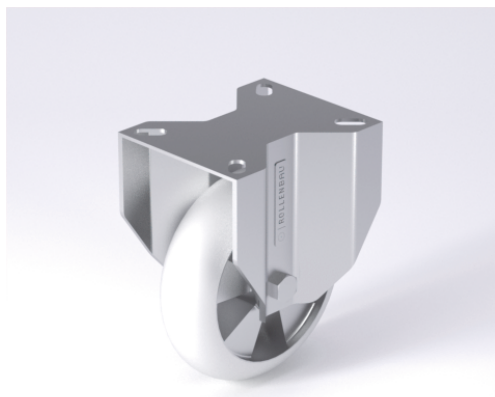

CD-EGBA



NEU!

Lenkrolle Swivel Castor	Lenkrolle mit Totlaststeller Swivel Castor with total lock	Bockrolle Fixed Castor
<ul style="list-style-type: none"> sehr geräuscharmer Lauf sehr geringer Rollwiderstand abriebfest korrosionsbeständig Alternative zu Luftrollen SPURFEST 	<ul style="list-style-type: none"> zweifaches Kugellager – verriegelt Stahlkugeln gehärtet, Dichtungsring, Radnabe verschraubt, verzinkt 	<ul style="list-style-type: none"> Auswahlhilfe Selection Criteria leicht lenkend/swivels easily verschleißarm/wear resistant staubfest/dust proof bodenschonend/floor protective witterungsbeständig/weather proof
<ul style="list-style-type: none"> Elastik-Vollgummireifen 55 ± 3 Shore A ballig Felge aus Spritzguss-Aluminium-Legierung → Seite/Page 345 	→ Seite/Page 112	

Technische Details

ORDERNO (Artikel-nummer)	CDF 200 EGBAK
WDAB (Rad-Ø A x Breite B / mm)	200x50
LC (Tragkraft / kg)	300
H (Bauhöhe H / mm)	240
TP (Plattengröße / mm)	135x110
HS (Lochabstand / mm)	105x80
HD (Loch-Ø / mm)	11
SR (Schwenkradius / mm)	159
WB (Radlager)	Kugellager