

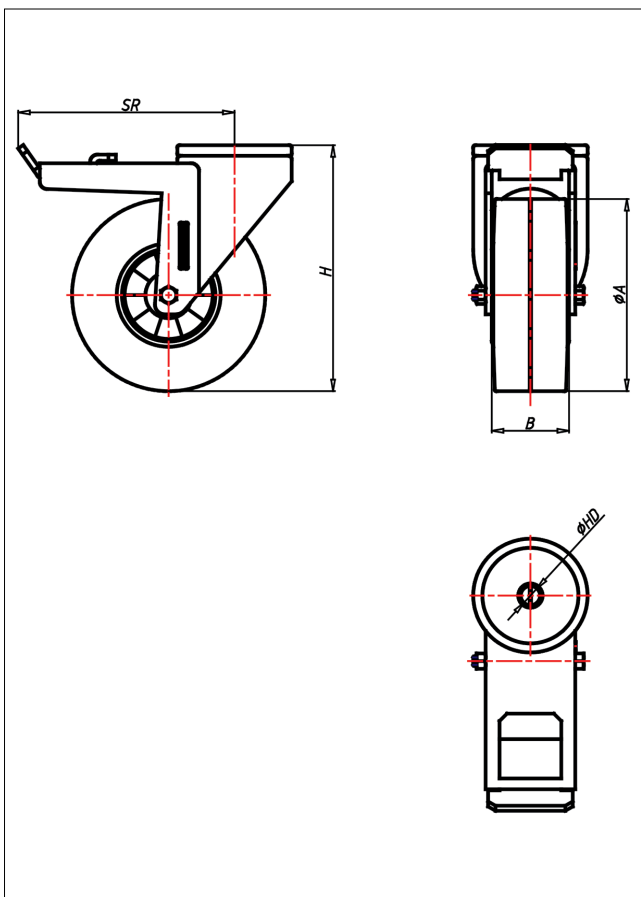

CRT/CRST- EK/EB/LEK/LEB

Lenkrolle mit Totalfeststeller



CR-E



+70 °C
-20 °C max. 300 kg

LENKROLLE	LENKROLLE MIT TOTALFESTSTELLER																					
																						
<ul style="list-style-type: none"> • hoher Fahrkomfort • sehr laufruhig • geringer Rollwiderstand • abriebfest • spurfrei in grau 	 zweifaches Kugellager - vernietet Stahlkugeln gehärtet Radachse verschraubt, verzinkt → Seite 62	AUSWAHLHILFE: <table border="0"> <tr> <td>leicht lenkend</td> <td>+</td> <td>+</td> <td>+</td> </tr> <tr> <td>verschleißarm</td> <td>x</td> <td>x</td> <td>x</td> </tr> <tr> <td>stoßfest</td> <td>+</td> <td>+</td> <td>+</td> </tr> <tr> <td>bodenschonend</td> <td>+</td> <td>+</td> <td>+</td> </tr> <tr> <td>witterungsbeständig</td> <td>x</td> <td>x</td> <td>x</td> </tr> </table>	leicht lenkend	+	+	+	verschleißarm	x	x	x	stoßfest	+	+	+	bodenschonend	+	+	+	witterungsbeständig	x	x	x
leicht lenkend	+	+	+																			
verschleißarm	x	x	x																			
stoßfest	+	+	+																			
bodenschonend	+	+	+																			
witterungsbeständig	x	x	x																			
ELASTIK-Vollgummi Felge Spritzguss- Aluminiumlegierung → Seite 259																						

Technische Details

ORDERNO (Artikel-nummer)	CRST 125 EB
WDAB (Rad-Ø A x Breite B / mm)	125x50
LC (Tragkraft / kg)	170
H (Bauhöhe H / mm)	160
HD (Loch-Ø / mm)	12.5
SR (Schwenkradius / mm)	140
WB (Radlager)	Rollenlager