

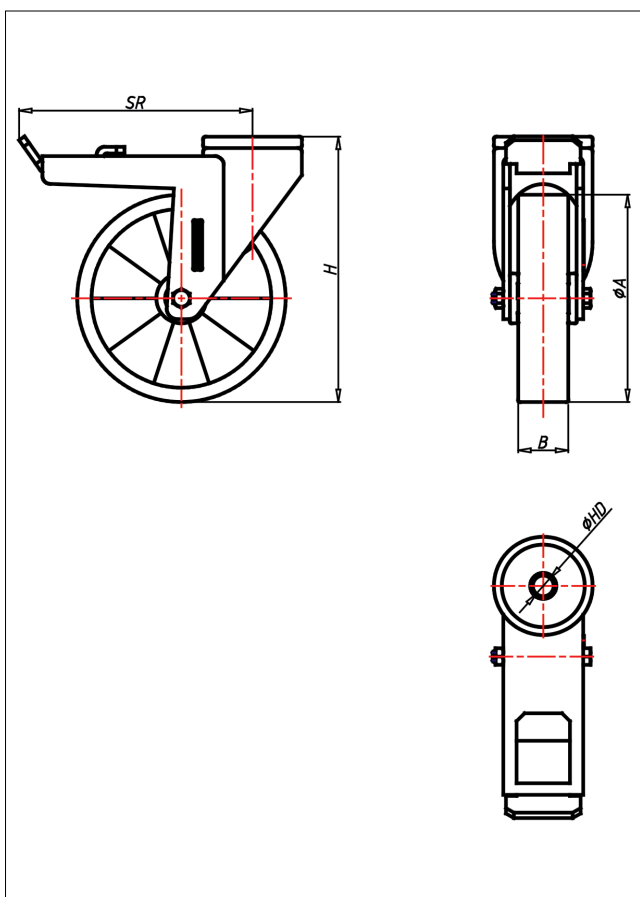

# CRT/CRST-TLK/TLB

## Lenkrolle mit Totalfeststeller



### CR-TL



LENKROLLE	LENKROLLE MIT TOTALFESTSTELLER																			
<ul style="list-style-type: none"> <li>geräuscharmer Lauf</li> <li>geringer Rollwiderstand</li> <li>abrieb- und reißfest</li> <li>hohe Stoßfestigkeit</li> <li>sehr beständig gegen viele aggressive Medien</li> </ul> Guss-Polyurethan Felge Spritzguss-Aluminium-Legierung → Seite 250	zweifaches Kugellager - vernietet Stahlkugeln gehärtet Radachse verschraubt, verzinkt → Seite 62	<b>AUSWAHLHILFE:</b> <table border="0"> <tr> <td>-</td><td>+</td><td>++</td> </tr> <tr> <td>leicht lenkend</td><td>X</td><td>X</td> </tr> <tr> <td>verschleißarm</td><td>○</td><td>○</td> </tr> <tr> <td>stoßfest</td><td>X</td><td>X</td> </tr> <tr> <td>bodenschonend</td><td>○</td><td>X</td> </tr> <tr> <td>witterungsbeständig</td><td>X</td><td>X</td> </tr> </table>	-	+	++	leicht lenkend	X	X	verschleißarm	○	○	stoßfest	X	X	bodenschonend	○	X	witterungsbeständig	X	X
-	+	++																		
leicht lenkend	X	X																		
verschleißarm	○	○																		
stoßfest	X	X																		
bodenschonend	○	X																		
witterungsbeständig	X	X																		

### Technische Details

<b>ORDERNO (Artikel-nummer)</b>	CRST 125 TLB
<b>WDAB (Rad-Ø A x Breite B / mm)</b>	125x30
<b>LC (Tragkraft / kg)</b>	200
<b>H (Bauhöhe H / mm)</b>	160
<b>HD (Loch-Ø / mm)</b>	12.5
<b>SR (Schwenkradius / mm)</b>	140
<b>WB (Radlager)</b>	Rollenlager