

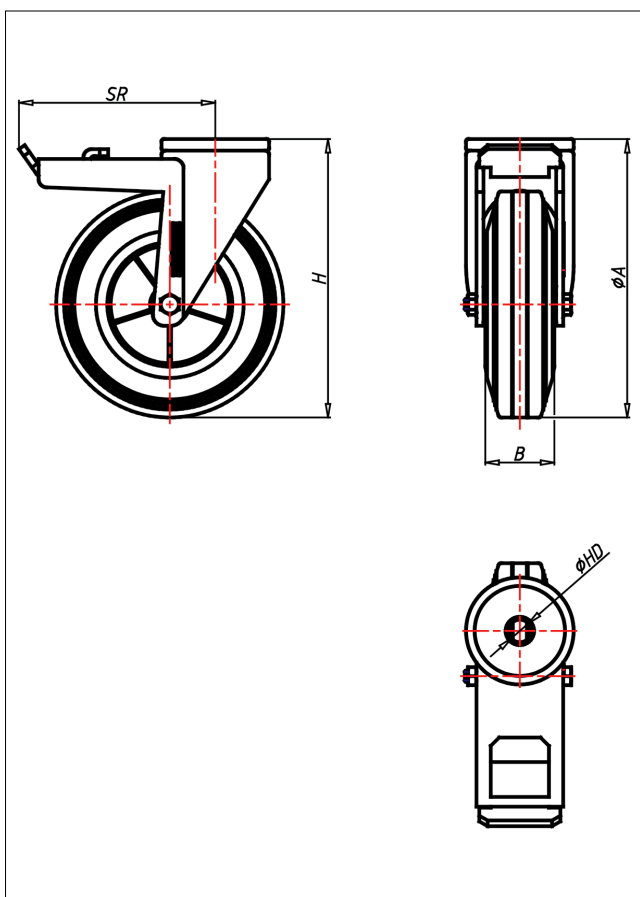

# CRT-DGB/DG

## Lenkrolle mit Totalfeststeller



### CR-DG



LENKROLLE	LENKROLLE MIT TOTALFESTSTELLER																			
<ul style="list-style-type: none"> <li>• spurfrei - bodenschonend</li> <li>• hoher Fahrkomfort</li> <li>• sehr lauffähig</li> <li>• geringer Rollwiderstand</li> <li>• abriebfest</li> </ul> ELASTIK-Vollgummi Felge Kunststoff → Seite 262	zweifaches Kugellager - vernietet Stahlkugeln gehärtet Radachse verschraubt, verzinkt → Seite 62	AUSWAHLHILFE: <table border="0"> <tr> <td>←</td> <td>+</td> <td>+</td> </tr> <tr> <td>leicht lenkend</td> <td>X</td> <td>X</td> </tr> <tr> <td>verschleißarm</td> <td>X</td> <td>X</td> </tr> <tr> <td>stoßfest</td> <td>X</td> <td>X</td> </tr> <tr> <td>bodenschonend</td> <td>X</td> <td>X</td> </tr> <tr> <td>witterungsbeständig</td> <td>X</td> <td>X</td> </tr> </table>	←	+	+	leicht lenkend	X	X	verschleißarm	X	X	stoßfest	X	X	bodenschonend	X	X	witterungsbeständig	X	X
←	+	+																		
leicht lenkend	X	X																		
verschleißarm	X	X																		
stoßfest	X	X																		
bodenschonend	X	X																		
witterungsbeständig	X	X																		

### Technische Details

<b>ORDERNO (Artikel-nummer)</b>	CRT 125 DGB
<b>WDAB (Rad-Ø A x Breite B / mm)</b>	125x38
<b>LC (Tragkraft / kg)</b>	110
<b>H (Bauhöhe H / mm)</b>	154
<b>HD (Loch-Ø / mm)</b>	12.5
<b>SR (Schwenkradius / mm)</b>	108
<b>WB (Radlager)</b>	Rollenlager