

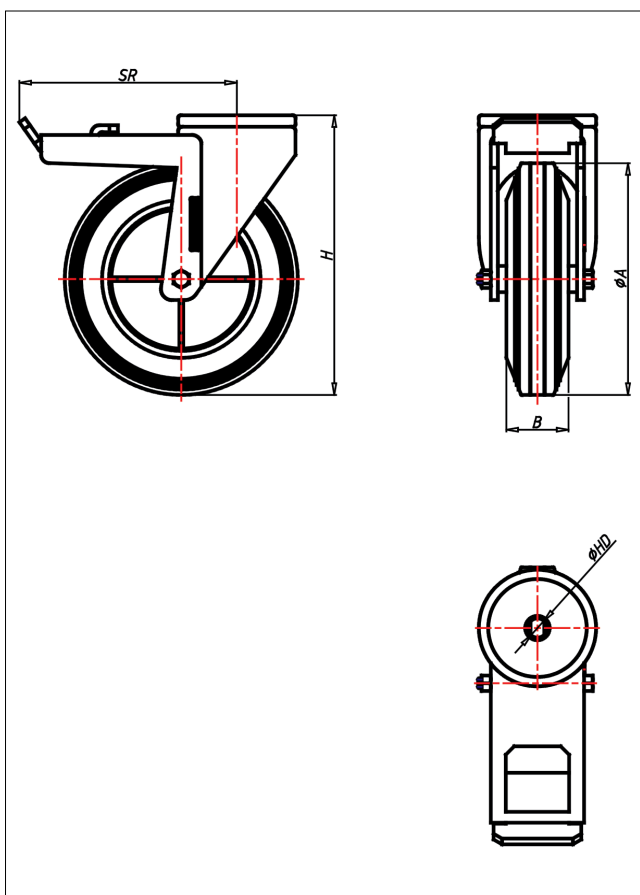

CRT-CK/CB

Lenkrolle mit Totalfeststeller



CR-C



| LENKROLLE | LENKROLLE MIT TOTALFESTSTELLER | | | | | | | | | | | | | | | | | | | |
|--|--|---|---|---|---|----------------|---|---|---------------|---|---|----------|---|---|---------------|---|---|---------------------|---|---|
| | | | | | | | | | | | | | | | | | | | | |
| <ul style="list-style-type: none"> • geräuscharmer Lauf • großer Fahrkomfort • beständig gegen verdünnte Säuren Vollgummi schwarz Felge Stahlblech verzinkt → Seite 205 | <ul style="list-style-type: none"> • zweifaches Kugellager - vernietet • Stahlkugeln gehärtet • Radachse verschraubt, verzinkt → Seite 62 | AUSWAHLHILFE: <table border="0"> <tr> <td>◀</td> <td>+</td> <td>+</td> </tr> <tr> <td>leicht lenkend</td> <td>X</td> <td>●</td> </tr> <tr> <td>verschleißarm</td> <td>●</td> <td>●</td> </tr> <tr> <td>stoßfest</td> <td>X</td> <td>●</td> </tr> <tr> <td>bodenschonend</td> <td>X</td> <td>●</td> </tr> <tr> <td>witterungsbeständig</td> <td>X</td> <td>●</td> </tr> </table> | ◀ | + | + | leicht lenkend | X | ● | verschleißarm | ● | ● | stoßfest | X | ● | bodenschonend | X | ● | witterungsbeständig | X | ● |
| ◀ | + | + | | | | | | | | | | | | | | | | | | |
| leicht lenkend | X | ● | | | | | | | | | | | | | | | | | | |
| verschleißarm | ● | ● | | | | | | | | | | | | | | | | | | |
| stoßfest | X | ● | | | | | | | | | | | | | | | | | | |
| bodenschonend | X | ● | | | | | | | | | | | | | | | | | | |
| witterungsbeständig | X | ● | | | | | | | | | | | | | | | | | | |

Technische Details

| | |
|--------------------------------|-------------|
| ORDERNO (Artikel-nummer) | CRT 160 CB |
| WDAB (Rad-Ø A x Breite B / mm) | 160x40 |
| LC (Tragkraft / kg) | 180 |
| H (Bauhöhe H / mm) | 191 |
| HD (Loch-Ø / mm) | 12.5 |
| SR (Schwenkradius / mm) | 168 |
| WB (Radlager) | Rollenlager |