

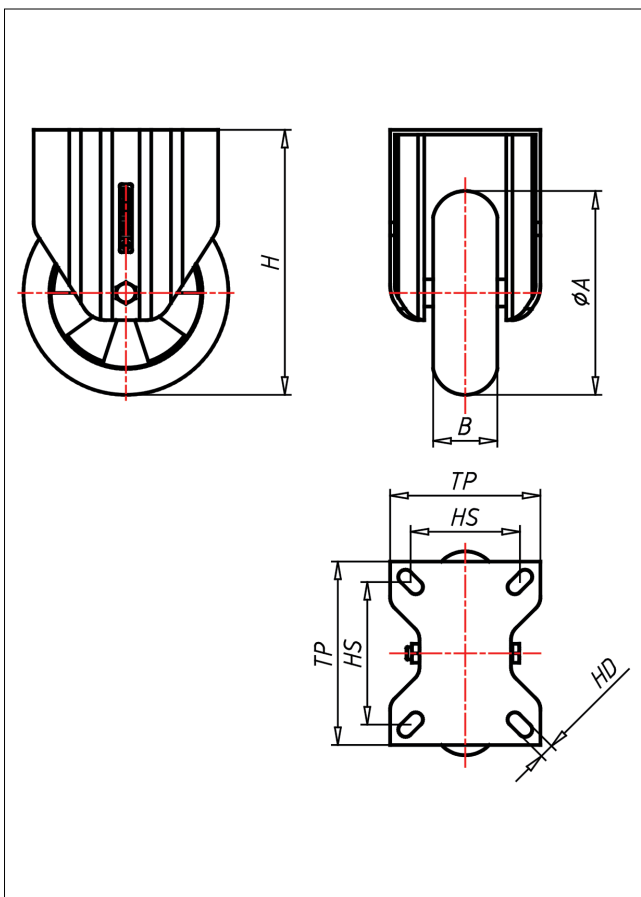

CDF/CSF-EBAK

Bockrolle

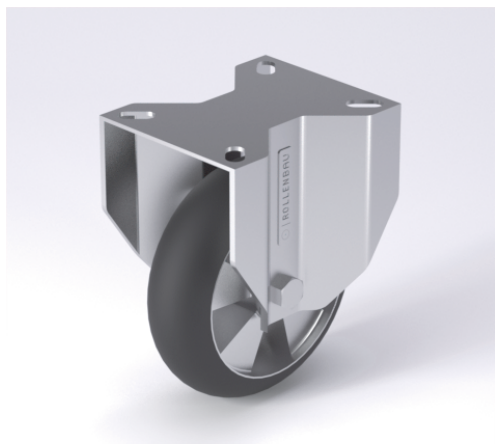

CD-EBA



LEUKROLLE Swivel Castor	LEUKROLLE mit Totallock Swivel Castor with total lock	Bockrolle Fixed Castor
<ul style="list-style-type: none"> sehr geruscharmer Lauf sehr geringer Rollwiderstand abriebfest korrosionsbeständig Alternative zu Luftreifen 	<ul style="list-style-type: none"> zweifaches Kugellager – vernietet Stahlkugeln gehärtet Dichtungsring Büchse verschraubt, verzinkt 	<ul style="list-style-type: none"> Auswahlhilfe Selection Criteria leicht lenkbar/steers easily verschleißarm/wear resistant staubdicht/dust proof bodenschonend/floor protective witterungsbeständig/weather proof
<ul style="list-style-type: none"> Elastik-Vollgummilaufläuf 55 ± 3 Shore A ballig Felge aus Spritzguss-Aluminium-Legierung → Seite/Page 343 	<ul style="list-style-type: none"> → Seite/Page 112 	

Technische Details

ORDERNO (Artikel-nummer)	CSF 160 EBAK
WDAB (Rad-Ø A x Breite B / mm)	160x50
LC (Tragkraft / kg)	270
H (Bauhöhe H / mm)	196
TP (Plattengröße / mm)	135x110
HS (Lochabstand / mm)	105x80
HD (Loch-Ø / mm)	11
SR (Schwenkradius / mm)	136
WB (Radlager)	Kugellager