

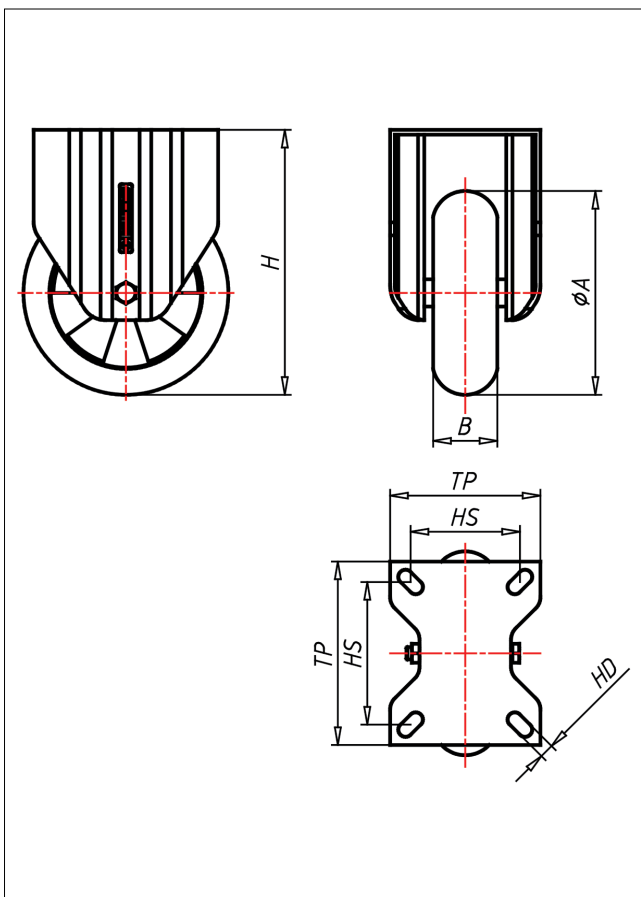

CDF-EGBAK

Bockrolle

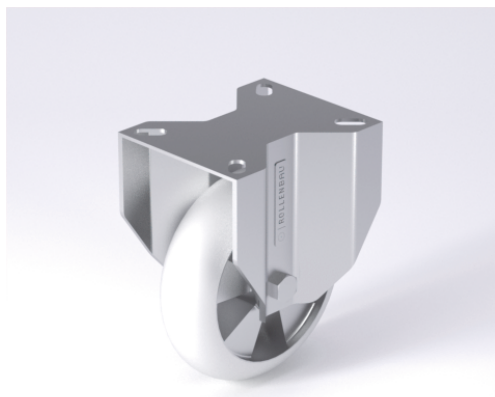

CD-EGBA



NEU!	Lenkrolle Swivel Castor	Lenkrolle mit Totlaststeller Swivel Castor with total lock	Bockrolle Fixed Castor
	<ul style="list-style-type: none"> sehr geräuscharmer Lauf sehr geringer Rollwiderstand abriebfest korrosionsbeständig Alternative zu Luftrollen SPURFEST 	<ul style="list-style-type: none"> zweifaches Kugellager – verietet Stahlkugeln gehärtet, Dichtungsring, Radnabe verschraubt, verzinkt 	<p>Auswahlhilfe Selection Criteria</p> <ul style="list-style-type: none"> leicht lenkend/swivels easily verschleißarm/wear resistant staubdicht/dust proof bodenschonend/floor protective witterungsbeständig/weather proof
	<ul style="list-style-type: none"> Elastik-Vollgummireifen 55 ± 3 Shore A ballig Felge aus Spritzguss-Aluminium-Legierung → Seite/Page 345 	<ul style="list-style-type: none"> → Seite/Page 112 	

Technische Details

ORDERNO (Artikel-nummer)	CSSF 125 EGBAK
WDAB (Rad-Ø A x Breite B / mm)	125x40
LC (Tragkraft / kg)	200
H (Bauhöhe H / mm)	160
TP (Plattengröße / mm)	135x110
HS (Lochabstand / mm)	105x80
HD (Loch-Ø / mm)	11
SR (Schwenkradius / mm)	111.5
WB (Radlager)	Kugellager