

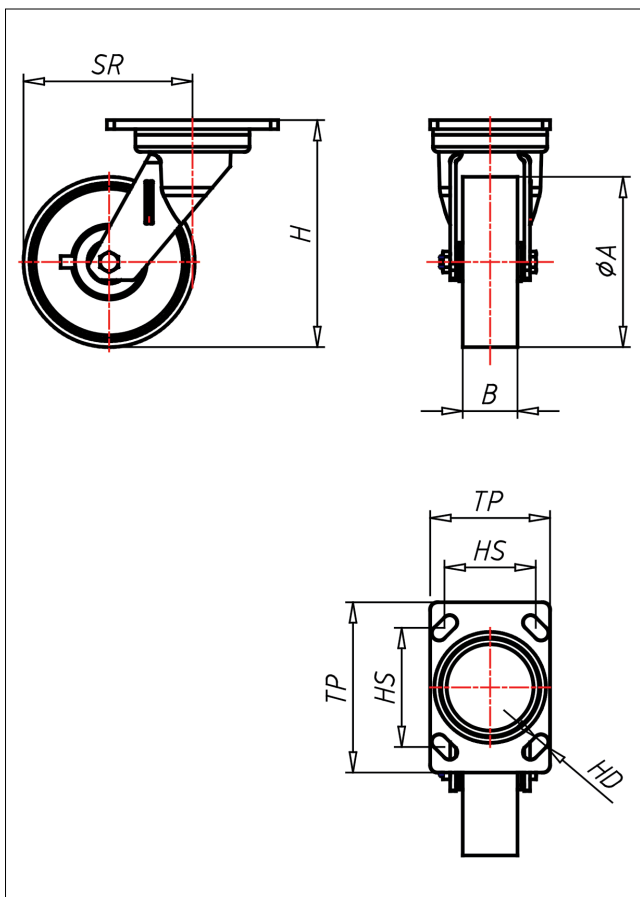

GT-PK/P

Lenkrolle

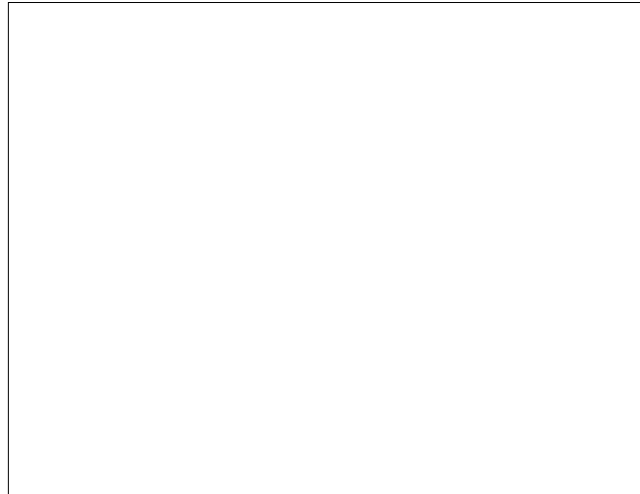

GT-P



LENKROLLE	RADFESTSTELLER	BOCKROLLE																				
<ul style="list-style-type: none"> • leichter Lauf auf glatten Böden • stoß- und schlagfest • hohe Abriebfestigkeit • leicht zu reinigen • sehr beständig gegen viele aggressive Medien Polyamid 6 - 1. Wahl → Seite 272	Schwerlastlenkgehäuse ohne Mittelbolzen mit gehärtetem Drehkranz und gehärteten Stahlkugeln, geschmiedet und getempert → Seite 42	AUSWAHLHILFE: <table border="1"> <tr> <td>leicht lenkend</td> <td>-</td> <td>+</td> <td>++</td> </tr> <tr> <td>verschleißarm</td> <td>x</td> <td></td> <td></td> </tr> <tr> <td>stoßfest</td> <td></td> <td>x</td> <td>x</td> </tr> <tr> <td>bodenschonend</td> <td></td> <td>x</td> <td></td> </tr> <tr> <td>witterungsbeständig</td> <td></td> <td>x</td> <td>x</td> </tr> </table>	leicht lenkend	-	+	++	verschleißarm	x			stoßfest		x	x	bodenschonend		x		witterungsbeständig		x	x
leicht lenkend	-	+	++																			
verschleißarm	x																					
stoßfest		x	x																			
bodenschonend		x																				
witterungsbeständig		x	x																			

Technische Details

ORDERNO (Artikel-nummer)	GT 151 PK
WDAB (Rad-Ø A x Breite B / mm)	150x48
LC (Tragkraft / kg)	900
H (Bauhöhe H / mm)	200
TP (Plattengröße / mm)	150x105
HS (Lochabstand / mm)	105x80
HD (Loch-Ø / mm)	13
SR (Schwenkradius / mm)	148
WB (Radlager)	Kugellager