

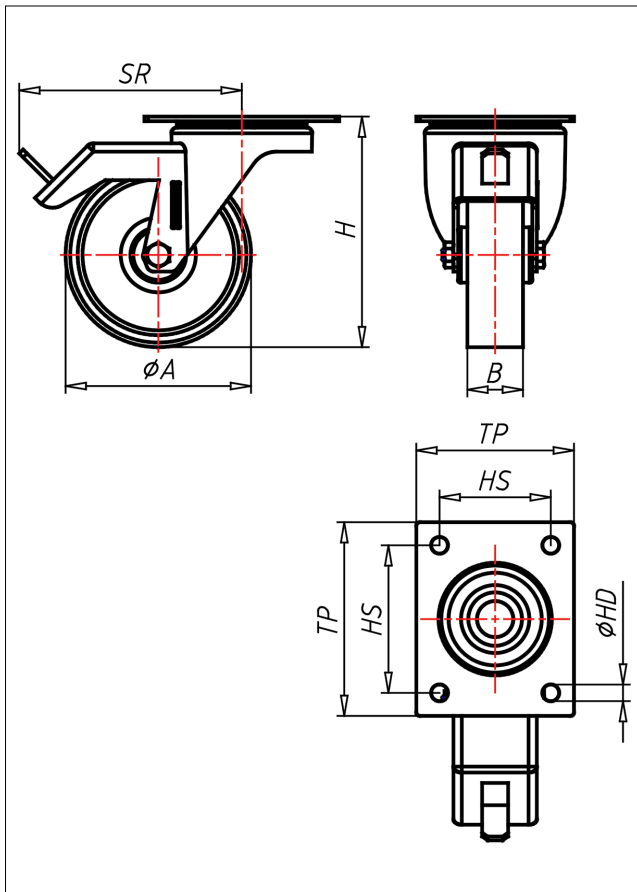

INT/INVT-ALBX/AL

Lenkrolle mit Totalfeststeller



IN-AL



LENKROLLE	LENKROLLE MIT TOTALFESTSTELLER	BOCKROLLE																		
 <ul style="list-style-type: none"> • geringer Rollwiderstand • abrieb- und reißfest • leichte Reinigung • sehr beständig gegen viele aggressive Medien Spritzguss-Polyurethan Felge Polyamid 6 → Seite 233	 <ul style="list-style-type: none"> • zweifaches Kugellager - verschraubt, Staubschutzring, Radachse verschraubt - gesichert, Edelstahl poliert → Seite 110	 <p>AUSWAHLHILFE:</p> <table border="0"> <tr> <td>-</td><td>+</td><td>++</td> </tr> <tr> <td>leicht lenkend</td><td>X</td><td></td> </tr> <tr> <td>verschleißarm</td><td></td><td>X</td> </tr> <tr> <td>stoßfest</td><td>X</td><td></td> </tr> <tr> <td>bodenschonend</td><td>X</td><td></td> </tr> <tr> <td>witterungsbeständig</td><td></td><td>X</td> </tr> </table>	-	+	++	leicht lenkend	X		verschleißarm		X	stoßfest	X		bodenschonend	X		witterungsbeständig		X
-	+	++																		
leicht lenkend	X																			
verschleißarm		X																		
stoßfest	X																			
bodenschonend	X																			
witterungsbeständig		X																		

Technische Details

ORDERNO (Artikel-nummer)	INT 150 ALBX
WDAB (Rad-Ø A x Breite B / mm)	150x40
LC (Tragkraft / kg)	250
H (Bauhöhe H / mm)	180
TP (Plattengröße / mm)	135x110
HS (Lochabstand / mm)	105x80
HD (Loch-Ø / mm)	11
SR (Schwenkradius / mm)	150
WB (Radlager)	Rollenlager