

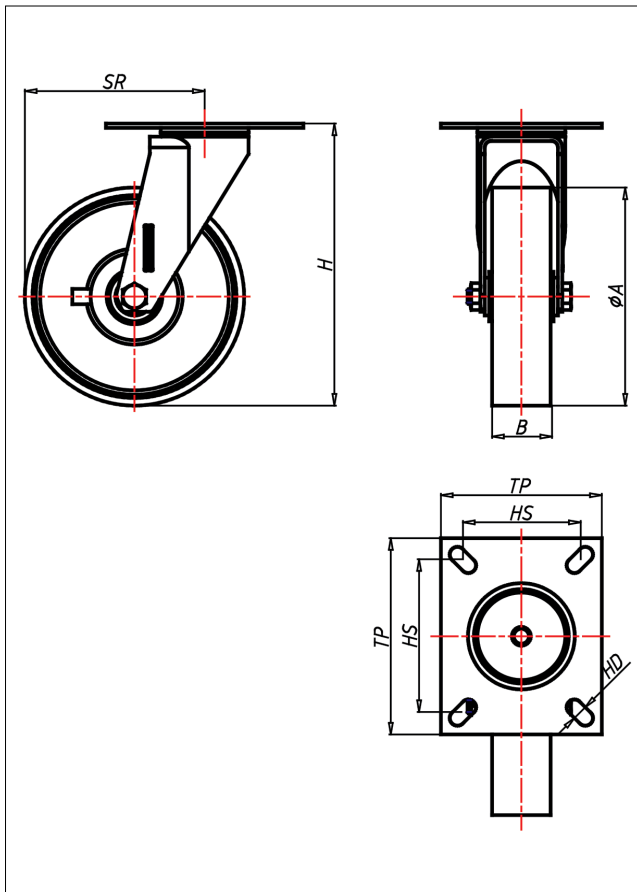

# KD/KS-PK/PB/P

## Lenkrolle



### KD-P



LENKROLLE	LENKROLLE MIT TOTALFESTSTELLER	BOCKROLLE																									
 <ul style="list-style-type: none"> <li>• leichter Lauf auf glatten Böden</li> <li>• stoß- und schlagfest</li> <li>• hohe Abriebfestigkeit</li> <li>• leicht zu reinigen</li> <li>• sehr beständig gegen viele aggressive Medien</li> </ul> <p>Polyamid 6 - 1. Wahl</p> <p>→ Seite 272</p> 	 <p><b>Laufkugeln gehärtet, Kugelbahnen gepresst, starker Zentralzapfen verschraubt - gedichtet - gesichert</b> Staubschutzring, verzinkt</p> <p>→ Seite 62</p>	 <p><b>AUSWAHLHILFE:</b></p> <table border="0"> <tr> <td>leicht lenkend</td> <td>+</td> <td>-</td> <td>+</td> <td>+</td> </tr> <tr> <td>verschleißarm</td> <td>+</td> <td>-</td> <td>x</td> <td>x</td> </tr> <tr> <td>stoßfest</td> <td>+</td> <td>-</td> <td>x</td> <td>x</td> </tr> <tr> <td>bodenschonend</td> <td>+</td> <td>-</td> <td>x</td> <td>x</td> </tr> <tr> <td>witterungsbeständig</td> <td>+</td> <td>-</td> <td>x</td> <td>x</td> </tr> </table>	leicht lenkend	+	-	+	+	verschleißarm	+	-	x	x	stoßfest	+	-	x	x	bodenschonend	+	-	x	x	witterungsbeständig	+	-	x	x
leicht lenkend	+	-	+	+																							
verschleißarm	+	-	x	x																							
stoßfest	+	-	x	x																							
bodenschonend	+	-	x	x																							
witterungsbeständig	+	-	x	x																							

### Technische Details

<b>ORDERNO (Artikel-nummer)</b>	KD 125 PK
<b>WDAB (Rad-Ø A x Breite B / mm)</b>	125x40
<b>LC (Tragkraft / kg)</b>	300
<b>H (Bauhöhe H / mm)</b>	163
<b>TP (Plattengröße / mm)</b>	135x110
<b>HS (Lochabstand / mm)</b>	105x80
<b>HD (Loch-Ø / mm)</b>	10.5
<b>SR (Schwenkradius / mm)</b>	104.5
<b>WB (Radlager)</b>	Kugellager