

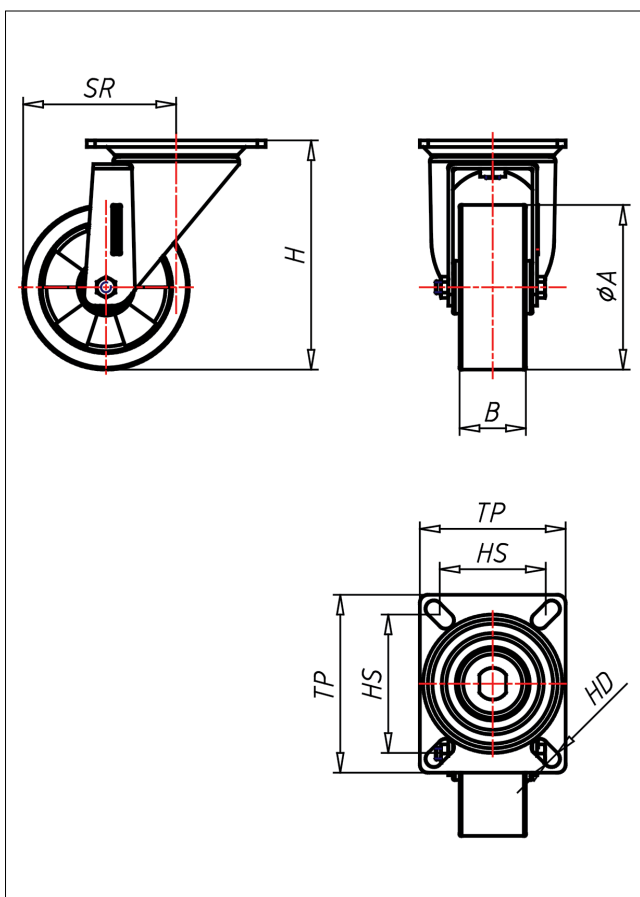

KD/KS-TLELK

Lenkrolle

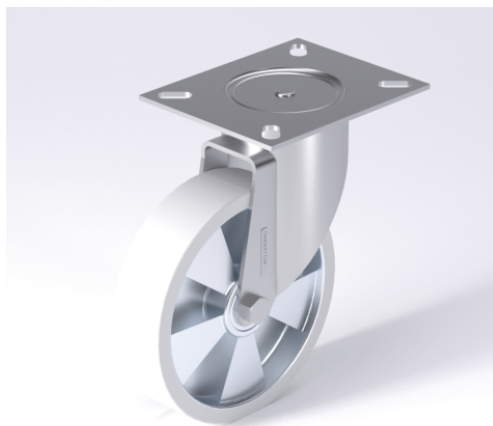

KD-TLEL



NEU!

Lenkrolle Swivel Castor	Lenkrolle mit Totalfeststeller Swivel Castor with total lock	Bockrolle Fixed Castor
<ul style="list-style-type: none"> elektrisch leitfähig geräuscharmer Lauf geringer Rollwiderstand streu- und rollfest spurfrei sehr beständig gegen viele aggressive Medien 	<ul style="list-style-type: none"> Laufkugeln gehärtet, Kugelbahnen gepresst, starker Zentralzapfen verschraubt - gedichtet - gesichert Staubschuttring, verzinkt 	<ul style="list-style-type: none"> Auswahlhilfe Selection Criteria leicht lenkbar/swivels easily verschleißarm/wear resistant stabil/floor good bodenschonend/floor protection witterungsbeständig/weather proof
<ul style="list-style-type: none"> Guss-Polyurethan 95s3 Shore A Felge Spritzguss-Aluminium-Legierung → Seite/Page 334 	→ Seite/Page 112	

Technische Details

ORDERNO (Artikel-nummer)	KS 160 TLELK
WDAB (Rad-Ø A x Breite B / mm)	160x50
LC (Tragkraft / kg)	500
H (Bauhöhe H / mm)	207
TP (Plattengröße / mm)	135x110
HS (Lochabstand / mm)	105x80
HD (Loch-Ø / mm)	12.5
SR (Schwenkradius / mm)	143
WB (Radlager)	Kugellager