

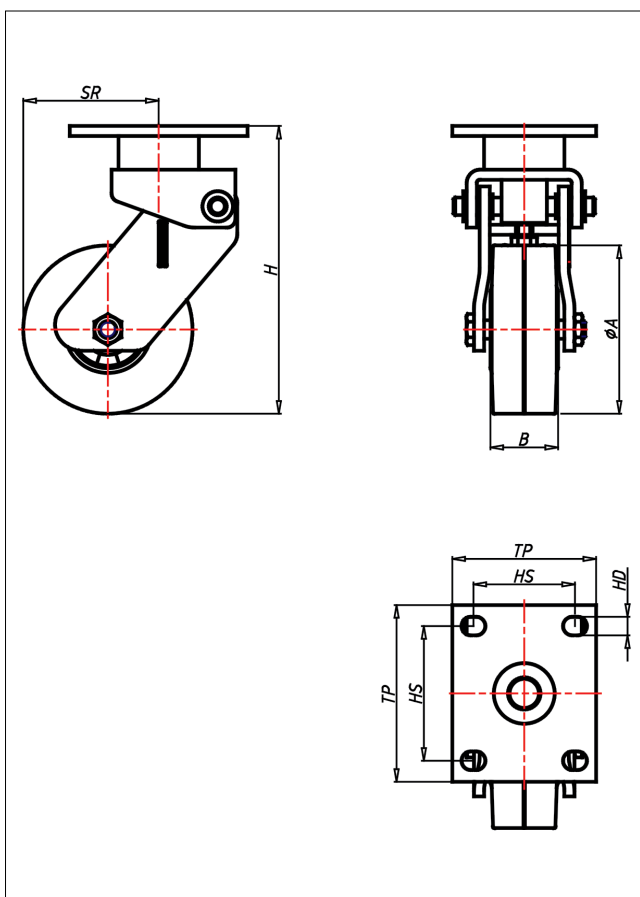

MFA/MFB/MFC- EK/EB/LEK/LEB

Lenkrolle



MFA-E



LENKROLLE	BOCKROLLE	
<ul style="list-style-type: none"> • hoher Fahrkomfort • sehr laufruhig • geringer Rollwiderstand • abriebfest • spurfrei in grau 	<ul style="list-style-type: none"> • zweifaches Kugellager • Polyurethan-Federelement • Schwinghebel auf Bronzebuchsen, schwarz lackiert 	<p>AUSWAHLHILFE:</p> <ul style="list-style-type: none"> leicht lenkend <input type="checkbox"/> <input checked="" type="checkbox"/> <input checked="" type="checkbox"/> verschleißarm <input type="checkbox"/> <input checked="" type="checkbox"/> <input checked="" type="checkbox"/> stoßfest <input type="checkbox"/> <input checked="" type="checkbox"/> <input checked="" type="checkbox"/> bodenschonend <input type="checkbox"/> <input checked="" type="checkbox"/> <input checked="" type="checkbox"/> witterungsbeständig <input type="checkbox"/> <input checked="" type="checkbox"/> <input checked="" type="checkbox"/>
<p>ELASTIK-Vollgummi Felge Spritzguss- Aluminiumlegierung → Seite 259</p>	<p>→ Seite 62</p>	

Technische Details

ORDERNO (Artikel-nummer)	MFA 160 EB
WDAB (Rad-Ø A x Breite B / mm)	160x50
LC (Tragkraft / kg)	220
PF (Vorspannkraft / daN)	90
MST (Max. Federweg / mm)	28
H (Bauhöhe H / mm)	238
TP (Plattengröße / mm)	135x110
HS (Lochabstand / mm)	105x80
HD (Loch-Ø / mm)	13
SR (Schwenkradius / mm)	123
WB (Radlager)	Rollenlager