

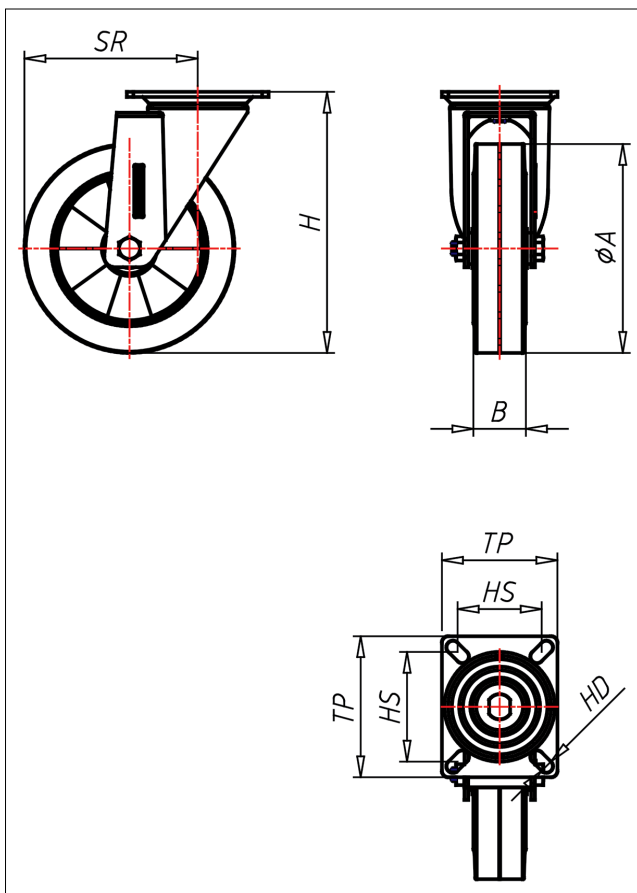

# PD/PS-EK/EB/LEK/LEB

## Lenkrolle

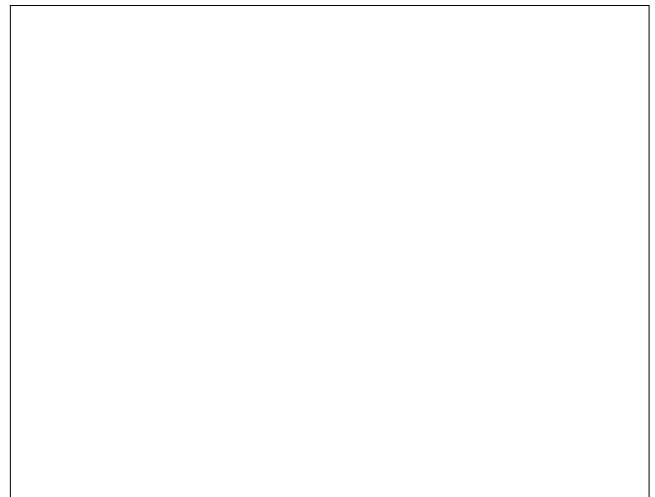

### PD-E



LENKROLLE	LENKROLLE MIT TOTALFESTSTELLER	BOCKROLLE
<ul style="list-style-type: none"> <li>• hoher Fahrkomfort</li> <li>• sehr lauf ruhig</li> <li>• geringer Rollwiderstand</li> <li>• abriebfest</li> <li>• spurfrei in grau</li> </ul>	<ul style="list-style-type: none"> <li>• gehärtete Stahlkugeln, zweifache Kugelbahnen aus gehärtetem Stahlblech, mit starkem Zentralzapfen verschraubt und gesichert - nachstellbar</li> </ul>	<p>AUSWAHLHILFE:</p> <ul style="list-style-type: none"> <li>leicht lenkend <input checked="" type="checkbox"/></li> <li>verschleißarm <input checked="" type="checkbox"/></li> <li>stoßfest <input checked="" type="checkbox"/></li> <li>bodenschonend <input checked="" type="checkbox"/></li> <li>witterungsbeständig <input checked="" type="checkbox"/></li> </ul>
<p>ELASTIK-Vollgummi Felge Spritzguss-Aluminiumlegierung → Seite 259</p>	<p>→ Seite 42</p>	

### Technische Details

<b>ORDERNO (Artikel-nummer)</b>	PD 250 EK
<b>WDAB (Rad-Ø A x Breite B / mm)</b>	250x60
<b>LC (Tragkraft / kg)</b>	450
<b>H (Bauhöhe H / mm)</b>	305
<b>TP (Plattengröße / mm)</b>	135x110
<b>HS (Lochabstand / mm)</b>	105x80
<b>HD (Loch-Ø / mm)</b>	12.5
<b>SR (Schwenkradius / mm)</b>	196
<b>WB (Radlager)</b>	Kugellager