

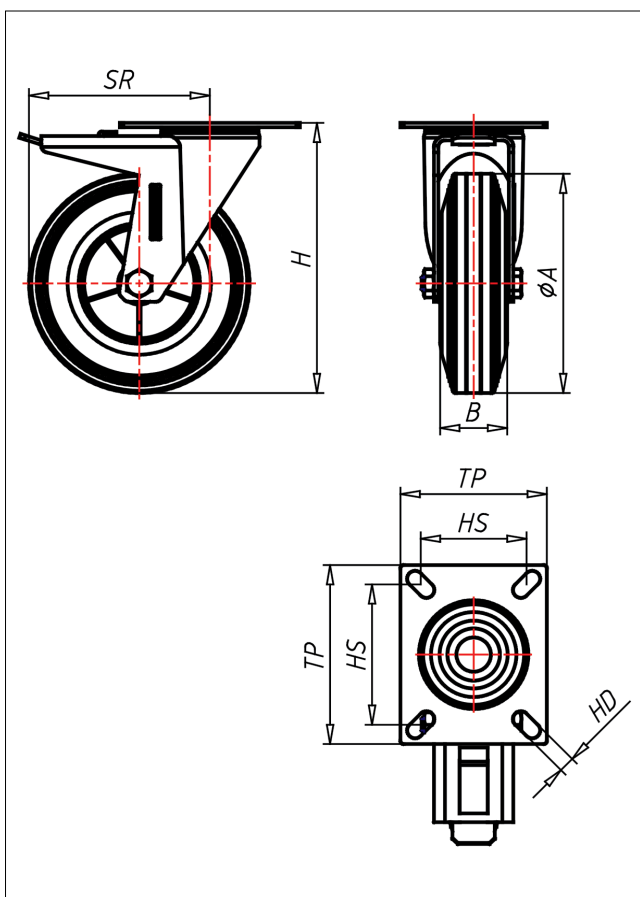

XDT/XLT-DGBX/DG

Lenkrolle mit Totalfeststeller



XD-DG



LENKROLLE	LENKROLLE MIT TOTALFESTSTELLER	BOCKROLLE																		
<ul style="list-style-type: none"> • spurfrei - bodenschonend • hoher Fahrkomfort • sehr laufruhig • geringer Rollwiderstand • abriebfest ELASTIK-Vollgummi Felge Kunststoff → Seite 252	<ul style="list-style-type: none"> • zweifaches Kugellager - vernietet, Edelstahl AISI 304 poliert, Laufkugeln AISI 420, Staubschutzring, Radachse verschraubt → Seite 110	AUSWAHLHILFE: <table border="0"> <tr> <td>•</td><td>+</td><td>++</td></tr> <tr> <td>leicht lenkend</td><td>X</td><td>●</td></tr> <tr> <td>verschleißarm</td><td>●</td><td>●</td></tr> <tr> <td>stoßfest</td><td>X</td><td>●</td></tr> <tr> <td>bodenschonend</td><td>●</td><td>X</td></tr> <tr> <td>witterungsbeständig</td><td>●</td><td>X</td></tr> </table>	•	+	++	leicht lenkend	X	●	verschleißarm	●	●	stoßfest	X	●	bodenschonend	●	X	witterungsbeständig	●	X
•	+	++																		
leicht lenkend	X	●																		
verschleißarm	●	●																		
stoßfest	X	●																		
bodenschonend	●	X																		
witterungsbeständig	●	X																		

Technische Details

ORDERNO (Artikel-nummer)	XDT 80 DGBX
WDAB (Rad-Ø A x Breite B / mm)	80x30
LC (Tragkraft / kg)	55
H (Bauhöhe H / mm)	106
TP (Plattengröße / mm)	102x83
HS (Lochabstand / mm)	80x60
HD (Loch-Ø / mm)	9
SR (Schwenkradius / mm)	108
WB (Radlager)	Rollenlager