

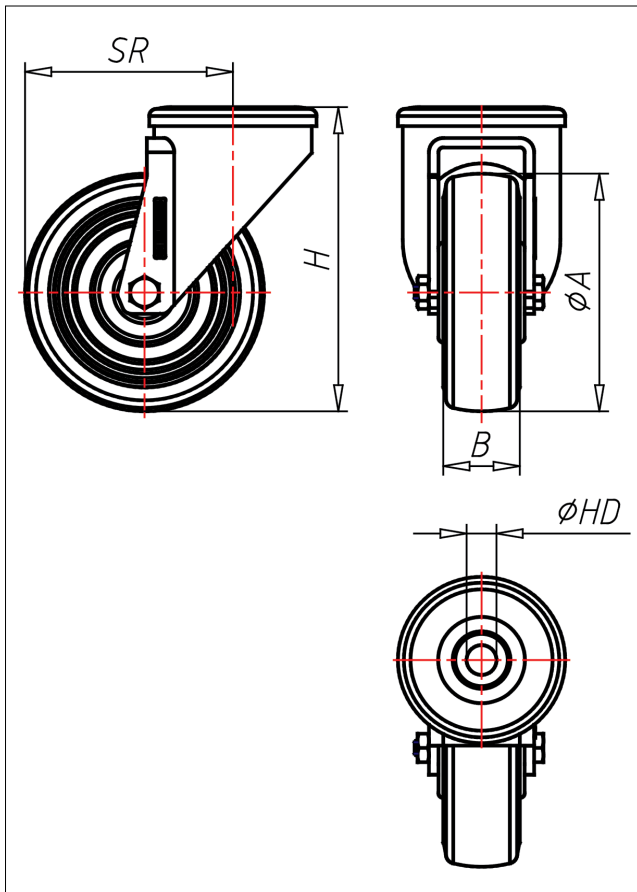

XR/XRS-AELK

Lenkrolle



XR-AEL



LENKROLLE	LENKROLLE MIT TOTALFESTSTELLER																					
																						
<ul style="list-style-type: none"> • elektrisch leifähig • geräuscharmer Lauf • geringer Rollwiderstand • spurfrei • hohe Stoßfestigkeit • sehr beständig gegen viele aggressive Medien <p>Polyurethan Felge Polyamid 6 → Seite 255</p> 	<p>zweifaches Kugellager - vernietet, Staubschuttring, Edelstahl AISI 304 poliert, Laufkugeln AISI 420, Radachse verschraubt → Seite</p>	<p>AUSWAHLHILFE:</p> <table border="0"> <tr> <td>leicht lenkend</td> <td>+</td> <td>+</td> <td>+</td> </tr> <tr> <td>verschleißarm</td> <td>+</td> <td>+</td> <td>+</td> </tr> <tr> <td>stoßfest</td> <td>+</td> <td>+</td> <td>+</td> </tr> <tr> <td>bodenschonend</td> <td>+</td> <td>+</td> <td>+</td> </tr> <tr> <td>witterungsbeständig</td> <td>+</td> <td>+</td> <td>+</td> </tr> </table>	leicht lenkend	+	+	+	verschleißarm	+	+	+	stoßfest	+	+	+	bodenschonend	+	+	+	witterungsbeständig	+	+	+
leicht lenkend	+	+	+																			
verschleißarm	+	+	+																			
stoßfest	+	+	+																			
bodenschonend	+	+	+																			
witterungsbeständig	+	+	+																			

Technische Details

ORDERNO (Artikel-nummer)	XRS 100 AELK
WDAB (Rad-Ø A x Breite B / mm)	100x32
LC (Tragkraft / kg)	200
H (Bauhöhe H / mm)	129
HD (Loch-Ø / mm)	12.5
SR (Schwenkradius / mm)	96
WB (Radlager)	Rollenlager