

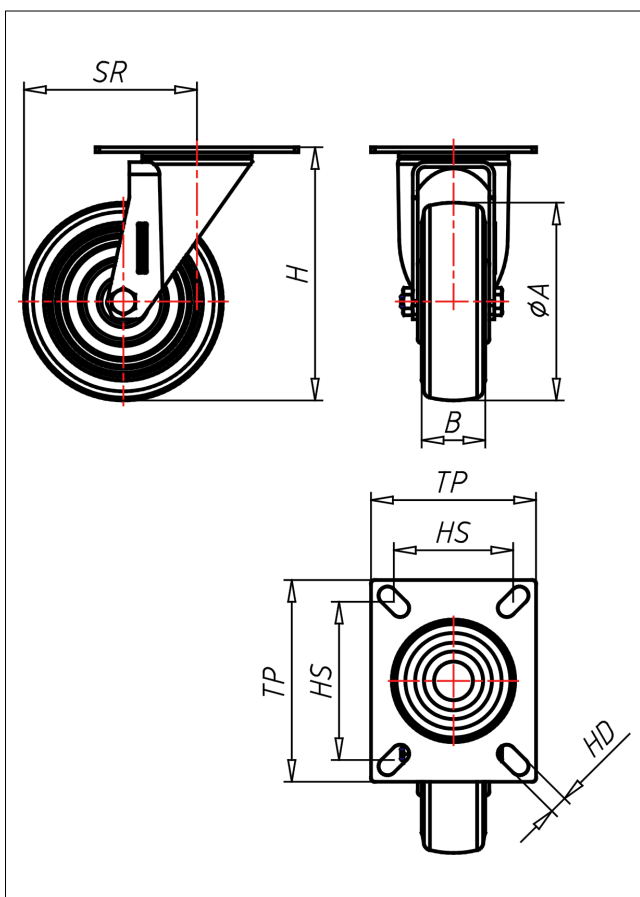

XD/XS/XSS-AELK

Lenkrolle

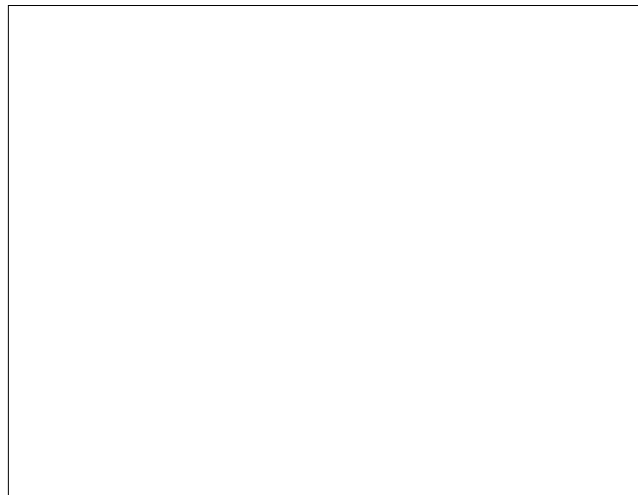

XD-AEL



LENKROLLE	LENKROLLE MIT TOTALFESTSTELLER	BOCKROLLE																		
 <ul style="list-style-type: none"> • elektrisch leitfähig • geräuscharmer Lauf • geringer Rollwiderstand • spurlos • hohe Stoßfestigkeit • sehr beständig gegen viele aggressive Medien <p>Polyurethan Felge Polyamid 6 → Seite 255</p> 	 <p>zweifaches Kugellager - vernietet, Edelstahl ANSI 304 poliert, Laufkugeln AISI 420, Staubschutzring, Radachse verschraubt</p> <p>→ Seite 110</p>	 <p>AUSWAHLHILFE:</p> <table border="0"> <tr> <td>-</td><td>+</td><td>++</td> </tr> <tr> <td>leicht lenkend</td><td>X</td><td></td> </tr> <tr> <td>verschleißarm</td><td></td><td>X</td> </tr> <tr> <td>stoßfest</td><td>X</td><td></td> </tr> <tr> <td>bodenschonend</td><td></td><td>X</td> </tr> <tr> <td>witterungsbeständig</td><td></td><td>X</td> </tr> </table>	-	+	++	leicht lenkend	X		verschleißarm		X	stoßfest	X		bodenschonend		X	witterungsbeständig		X
-	+	++																		
leicht lenkend	X																			
verschleißarm		X																		
stoßfest	X																			
bodenschonend		X																		
witterungsbeständig		X																		

Technische Details

ORDERNO (Artikel-nummer)	XS 100 AELK
WDAB (Rad-Ø A x Breite B / mm)	100x32
LC (Tragkraft / kg)	150
H (Bauhöhe H / mm)	129
TP (Plattengröße / mm)	102x83
HS (Lochabstand / mm)	80x60
HD (Loch-Ø / mm)	9
SR (Schwenkradius / mm)	97
WB (Radlager)	Kugellager