

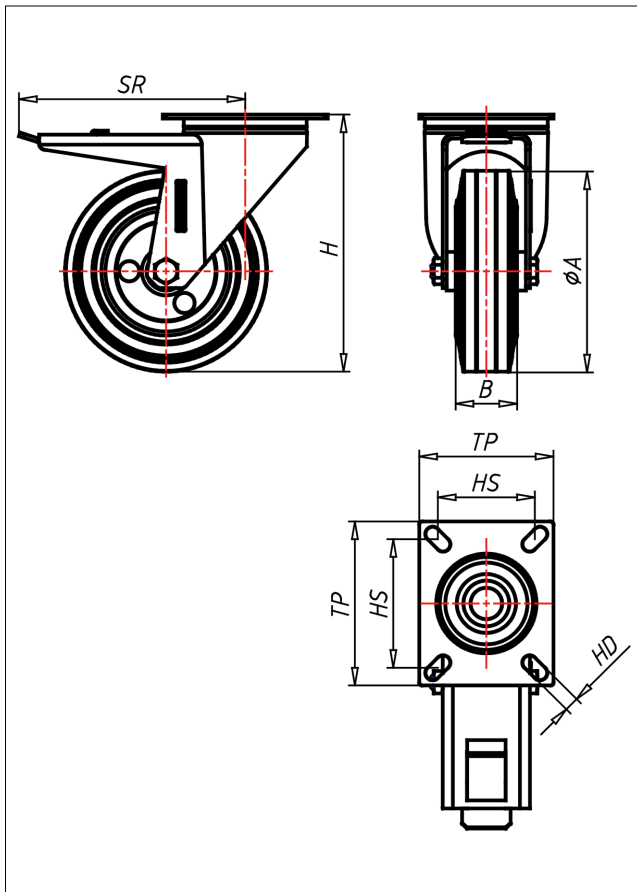

XDT/XST/XSST-ELBX

Lenkrolle mit Totalfeststeller

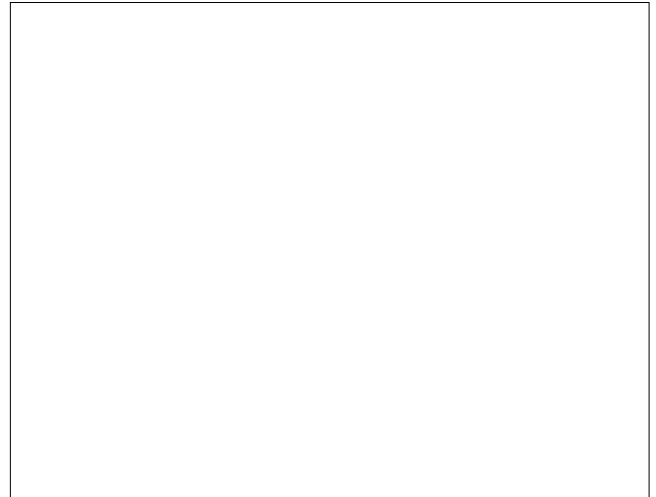

XD-EL



LENKROLLE	LENKROLLE MIT TOTALFESTSTELLER	BOCKROLLE															
<ul style="list-style-type: none"> • elektrisch leitfähig • Widerstand <math><10^{\circ}\Omega</math> • geräuscharmer Lauf • großer Fahrkomfort • beständig gegen verdünnte Säuren Vollgummi schwarz Felge aus Edelstahl → Seite 207	<ul style="list-style-type: none"> • zweifaches Kugellager - vernietet • Edelstahl ANSI 304 poliert, Laufkugeln ANSI 420, Staubschutzring, Radachse verschraubt → Seite 110	AUSWAHLHILFE: <table border="1"> <tr> <td>leicht lenkend</td> <td>+</td> <td>+</td> </tr> <tr> <td>verschleißarm</td> <td>x</td> <td>+</td> </tr> <tr> <td>stoßfest</td> <td>x</td> <td>+</td> </tr> <tr> <td>bodenschonend</td> <td>x</td> <td>+</td> </tr> <tr> <td>witterungsbeständig</td> <td>x</td> <td>+</td> </tr> </table>	leicht lenkend	+	+	verschleißarm	x	+	stoßfest	x	+	bodenschonend	x	+	witterungsbeständig	x	+
leicht lenkend	+	+															
verschleißarm	x	+															
stoßfest	x	+															
bodenschonend	x	+															
witterungsbeständig	x	+															

Technische Details

ORDERNO (Artikel-nummer)	XST 125 ELBX
WDAB (Rad-Ø A x Breite B / mm)	125x38
LC (Tragkraft / kg)	100
H (Bauhöhe H / mm)	160
TP (Plattengröße / mm)	102x83
HS (Lochabstand / mm)	80x60
HD (Loch-Ø / mm)	9
SR (Schwenkradius / mm)	140
WB (Radlager)	Rollenlager