

# 69-BA

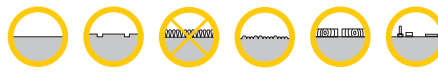

+80 °C  
-30 °C

kg max.  
800 kg



**Lenkrolle**  
Swivel Castor

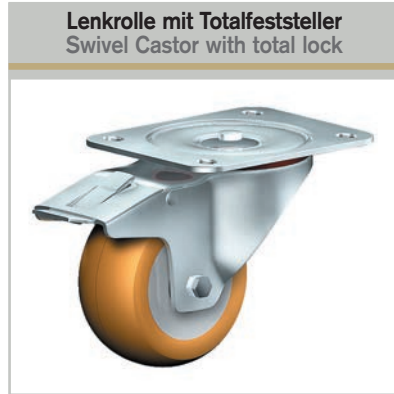

**Lenkrolle mit Totalfeststeller**  
Swivel Castor with total lock



**90° Richtungsfeststeller**  
90° Directional Lock

- minimaler Rollwiderstand
- geräuscharmer Lauf
- sehr niedrige Abriebswerte
- lange Lebensdauer
- sehr beständig gegen viele aggressive Medien



sehr großes Schwenklager, Staubschutzring, starker Zentralbolzen  
**verschraubt – gesichert**



Vulkollan®  
Reifen ballig gegossen  
Felge - Vollkern aus Aluminium

**Auswahlhilfe**

Selection Criteria

	<input type="radio"/>	<input type="radio"/>	<input type="radio"/>
leicht lenkend/swivels easily	<input type="radio"/>	<input type="radio"/>	<input checked="" type="radio"/>
verschleißarm/wear resistant	<input type="radio"/>	<input type="radio"/>	<input checked="" type="radio"/>
stoßfest/shock proof	<input type="radio"/>	<input type="radio"/>	<input checked="" type="radio"/>
bodenschonend/floor protective	<input type="radio"/>	<input type="radio"/>	<input checked="" type="radio"/>
witterungsbeständig/weather proof	<input type="radio"/>	<input checked="" type="radio"/>	<input type="radio"/>

ZEILE	Rad-Ø A x Breite B mm		Tragkraft kg	Bauhöhe H mm	Plattengröße mm	Lochabstand mm	Loch-Ø mm	Schwenkradius mm	Radlager	Lenkrolle	Lenkrolle mit Totalfeststeller	Bockrolle
	Artikelnummer	€	Artikelnummer	€	Artikelnummer	€						
1	50 x 42	100	72	95x70	75x50	7	63		⊕ ⊕	69A/50-42/1*		
2	65 x 30	130	110	100x85	80x60	7	65,5		⊕ ⊕	69SP/65-30 BA		
3	80 x 40	250	108	135x105	105x80	11	88		⊕ ⊕	69A/80-40 BA		
4	100 x 40	280	125	135x105	105x80	11	98		⊕ ⊕	69A/100-40 BA		69B/100-40 BA
5	100 x 40	350	135	100x80	80x60	11	93		⊕ ⊕	69S/100-40 BA		
6	100 x 40	280	125	135x105	105x80	11	98	140	⊕ ⊕		69F/100-40 BA	
7	100 x 40	280	125	135x105	105x80	11	98		⊕ ⊕		69R/100-40 BA**	
8	125 x 45	500	165	140x110	105x80	14,5	110,5		⊕ ⊕	69S/125-45 BA		
9	150 x 45	700	185	135x105	105x80	14,5	117		⊕ ⊕	PS125-150 BA		
10	150 x 50	700	204	135x105	105x80	14,5	123		⊕ ⊕	69S/150-50 BA		69R/150-50 BA**
11	200 x 50	800	251	135x105	105x80	14,5	168		⊕ ⊕	69S/200-50 BA		

Gleitlager Plain Bearing    
  Polyamid-Gleitlager Nylon Plain Bearing    
  Rollenlager Roller Bearing    
  Kugellager Ball Bearing    
  Schrägrollenlager Tapered Roller Bearing

\* Flache Lauffläche • \*\* Lenkrolle mit 90° Richtungsfeststeller - 4 Stufen  
 © = eingetragene Marke der Bayer AG, Leverkusen  
 \* Flat tread • \*\* Swivel castor with 90° directional lock - 4 steps  
 © = registered trade mark of Bayer AG, Leverkusen

**Gegenplatte nach EN 12532**  
Counter plate according to EN 12532

105x85x3,5mm  
135x110x5 mm

**Befestigungsschrauben Stahl 8.8 verzinkt**  
Fixing bolts steel 8.8 zinc plated

M6x20mm  
M10x20mm  
M14x30 mm

**Fußschutz auf Anfrage**  
Foot guard on request

# Trapezroller Scene Shifter

kg max.  
800 kg



**Lenkrolle**  
Swivel Castor



- minimaler Rollwiderstand
- geräuscharmer Lauf
- sehr niedrige Abriebswerte
- lange Lebensdauer
- sehr beständig gegen viele aggressive Medien



2 Präzisions-Rillenkugellager, ausgezeichnete Manövrierbarkeit, Geradeausfahren auch in engen Räumen möglich



ANDERE RÄDER AUF ANFRAGE  
OTHER WHEELS ON REQUEST

→ Seite/Page 84

Vulkollan®  
Reifen ballig gegossen  
Felge - Vollkern aus Aluminium

ZEILE									Lenkrolle		
	Rad-Ø A x Breite B mm	Tragkraft kg	Bauhöhe H mm	Plattengröße mm	Lochabstand mm	Loch-Ø mm	Schwenkradius mm	Radlager	Artikelnummer	€	
1	35x25	300	85	85x85	55x55	11	95		Trapez-Roller 35*		
2	50x42	300	105	135x110	105x80	13	206		Trapez-Roller CR 50-42**		
3	65x30	390	110	135x110	105x80	13	206		Trapez-Roller 65 BA		
4	80x40	750	160	135x110	105x80	13	206		Trapez-Roller 80 BA		
5	100x40	800	170	135x110	105x80	13	256		Trapez-Roller 100 BA		

Gleitlager Plain Bearing    
 Polyamid-Gleitlager Nylon Plain Bearing    
 Rollenlager Roller Bearing    
 Kugellager Ball Bearing    
 Schrägrollenlager Tapered Roller Bearing

\* Räder aus Polyurethan • \*\* Flache Lauffläche  
 ® = eingetragene Marke der Bayer AG, Leverkusen  
 \* Polyurethane wheels • \*\* Flat tread  
 ® = registered trade mark of Bayer AG, Leverkusen

Gegenplatte nach EN 12532  
 Counter plate according to EN 12532

135x110x5 mm € 3,7

