

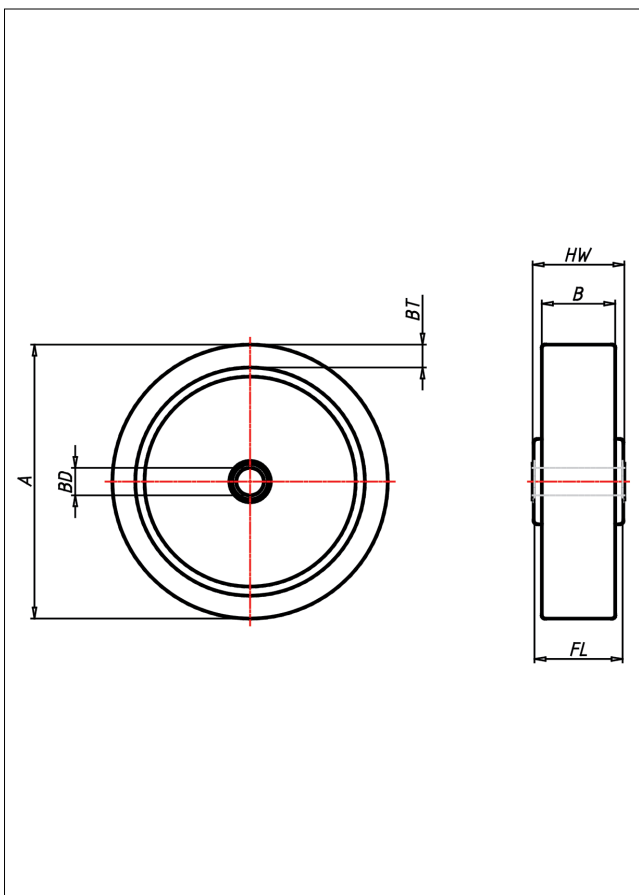

PS Rad

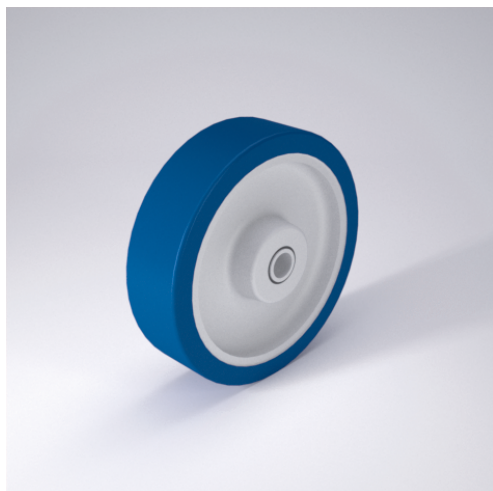

PS



+80 °C
-30 °C max. 600 kg



Radkörper aus Polyamid 6 - 1. Wahl
Laufbelag aus weichem Guss-Polyurethan,
87±3 Shore A

- sehr laufruhig
- geringer Rollwiderstand
- abrieb- und reißfest
- hohe Stoßfestigkeit
- leichte Reinigung
- sehr beständig gegen viele aggressive Medien

Technische Details

| | |
|---------------------------------------|-------------|
| ORDERNO (Artikel-nummer) | 125 PSB 15 |
| WDAB (Rad-Ø A x Breite B / mm) | 125x40 |
| LC (Tragkraft / kg) | 300 |
| BT (Reifenstärke / mm) | 12.5 |
| HW (Nabellänge / mm) | 40 |
| FL (Einbaulänge / mm) | 40 |
| WB (Radlager) | Rollenlager |
| BD (Bohrungsdurchmesser / mm) | 15 |