

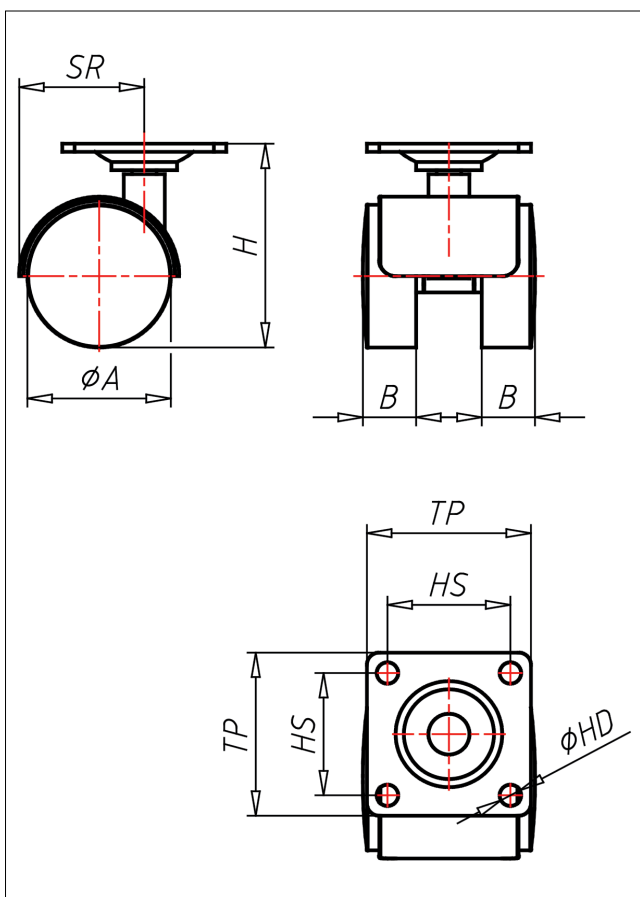

1800 PT G

Lenkrolle



1800-G



+60 °C max.
-20 °C 70 kg



schwarzes Gehäuse aus hochwertigem Kunststoff
Schwenklager mit Gleitlager Felge
aus hochwertigem Kunststoff Rad mit weicher Lauffläche - spurfrei
Radachse vernietet

Technische Details

ORDERNO (Artikel-nummer)	1800 PT 50 G
WDAB (Rad-Ø A x Breite B / mm)	50x12+12
LC (Tragkraft / kg)	50
H (Bauhöhe H / mm)	69
TP (Plattengröße / mm)	40x40
HS (Lochabstand / mm)	30x30
HD (Loch-Ø / mm)	5.2
SR (Schwenkradius / mm)	47
WB (Radlager)	Gleitlager