

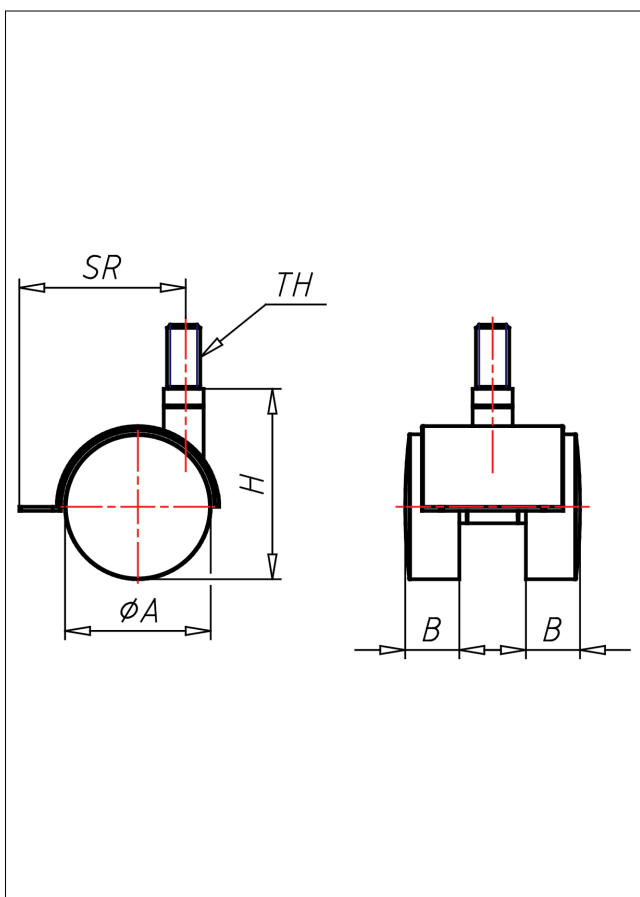

# 1801 M8/M10 P

## Lenkrolle mit Radfeststeller



1800-P



+60 °C  
-20 °C

kg max.  
70 kg



schwarzes Gehäuse aus  
hochwertigem Kunststoff  
Schwenklager mit Gleitlager Rad aus  
hochwertigem Kunststoff Radachse  
vernickelt

### Technische Details

ORDERNO (Artikel-nummer)	1801 M10 40 P
WDAB (Rad-Ø A x Breite B / mm)	40x10+10
LC (Tragkraft / kg)	40
H (Bauhöhe H / mm)	54
TH (Gewinde / mm)	M10x15
SR (Schwenkradius / mm)	59
WB (Radlager)	Gleitlager