

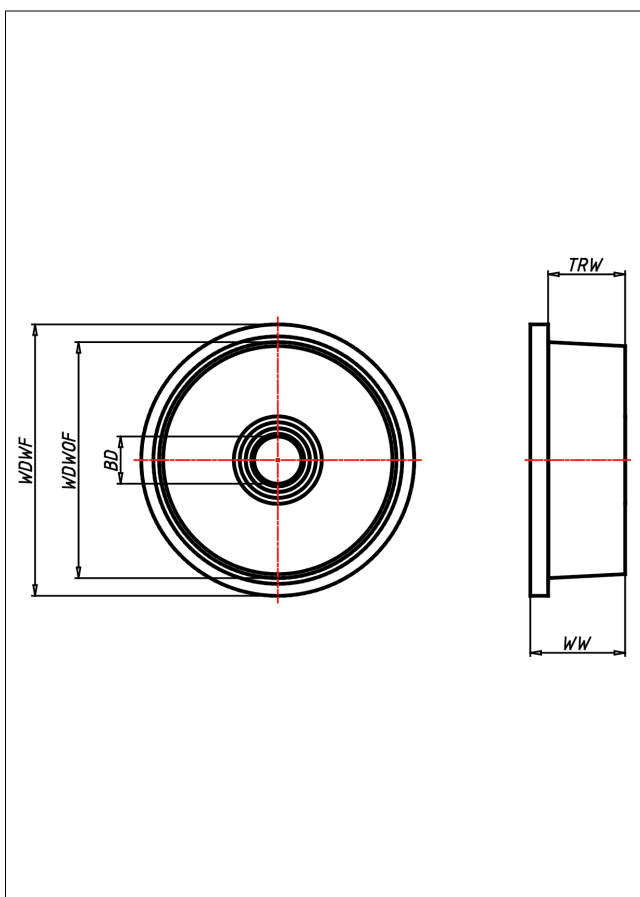

# SPE

## Spurkranzrad

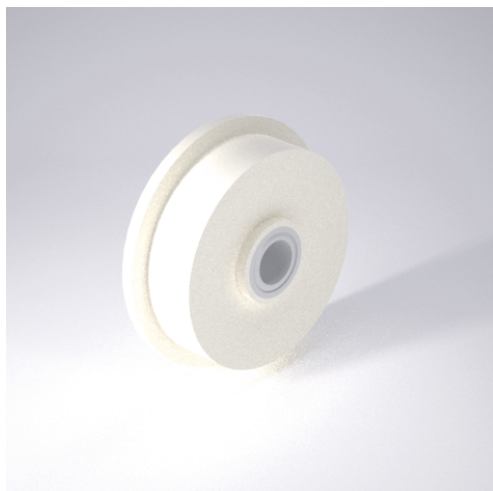

### SPE Spurkranzrad



Spurkranzrad aus hochverdichtetem, zähhartem Gusspolyamid, aus Vollmaterial gedreht  
Lauffläche 3° ansteigend

- geringer Rollwiderstand
- hohe Abriebfestigkeit
- sehr hohe Tragkraft

### Technische Details

ORDERNO (Artikel-nummer)	250 SPEK 50
WDWOF (Rad-Ø o. Spurkranz / mm)	250
WDFW (Rad-Ø m. Spurkranz / mm)	290
TRW (Laufflächenbreite / mm)	60
WW (Radbreite / mm)	75
LC (Tragkraft / kg)	4500
HW (Nabellänge / mm)	75
WB (Radlager)	2 Rillen-Kugellager ZZ
BD (Bohrungsdurchmesser / mm)	50