

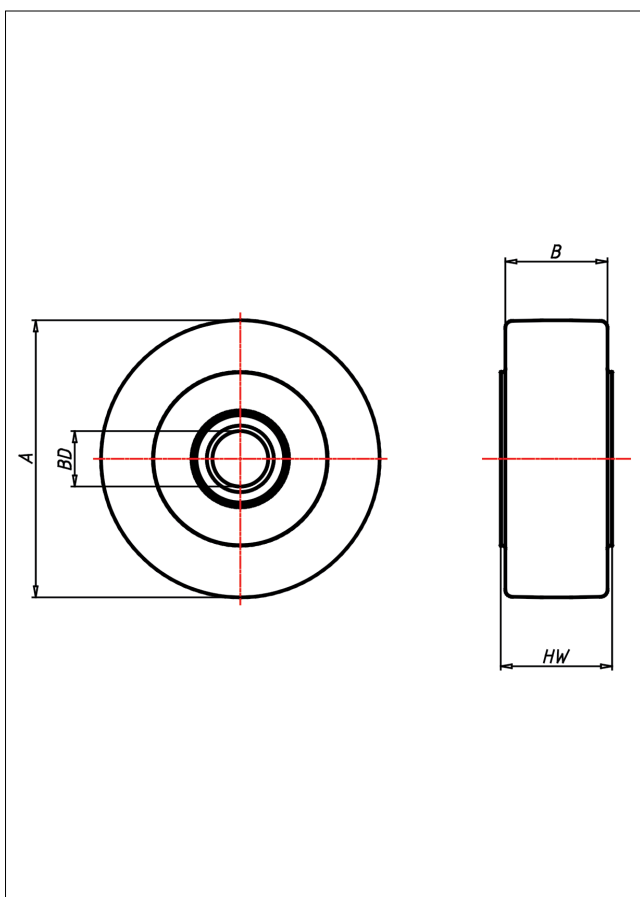

PE Rad

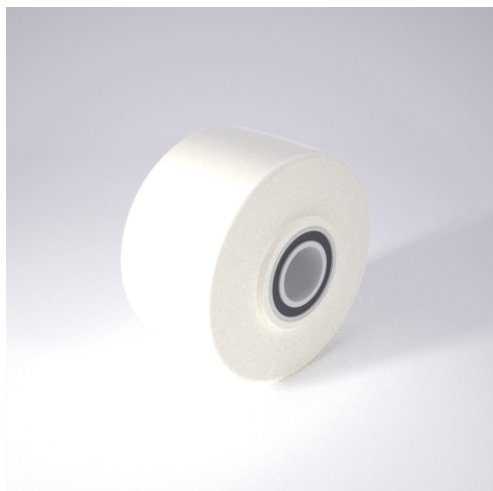

PE

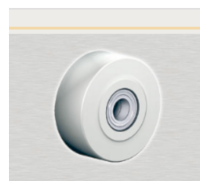

Vollrad aus Guss-Polyamid 6 - 1. Wahl

- für extra schwere Lasten
- leichter Lauf auf glatten Böden
- stoß- und schlagfest
- hohe Abriebfestigkeit
- leicht zu reinigen
- sehr beständig gegen viele aggressive Medien

Technische Details

ORDERNO (Artikel-nummer)	301 PEK 70
WDAB (Rad-Ø A x Breite B / mm)	300x110
LC (Tragkraft / kg)	10000
HW (Nabellänge / mm)	120
FL (Einbaulänge / mm)	120
WB (Radlager)	2 Rillen-Kugellager 6314 2RS
BD (Bohrungsdurchmesser / mm)	70