

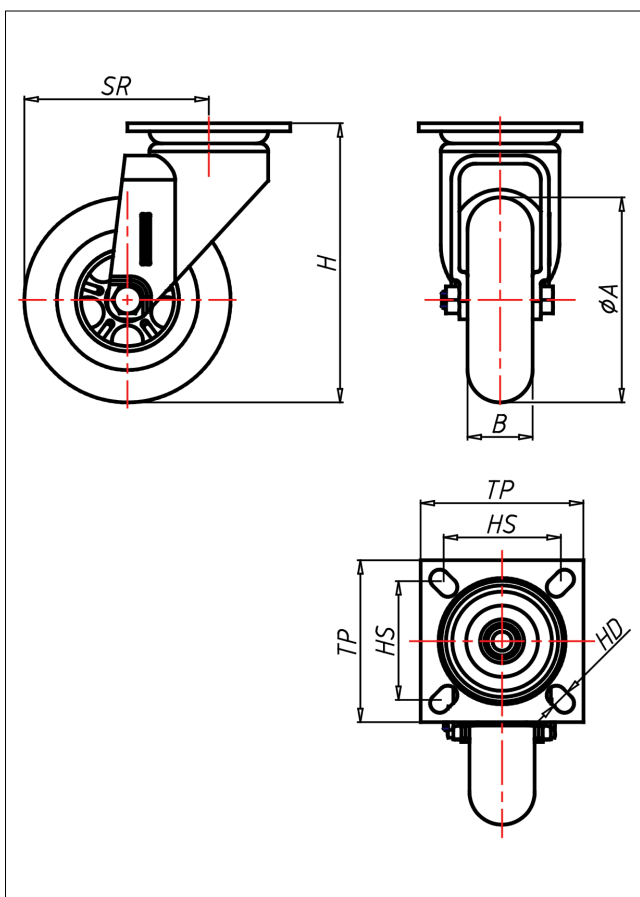

310X PT-V/SKA/TPKX

Lenkrolle



310XP-TP



LENKROLLE	LENKROLLE MIT TOTALFESTSTELLER	RAD SERIE SKA																				
<ul style="list-style-type: none"> geräuscharmer Lauf geringer Rollwiderstand abrieb- und reißfest hohe Stoßfestigkeit spurfrei sehr beständig gegen viele aggressive Medien Thermoplastisches Elastomer Felge Polyamid 6 → Seite 269	zweifaches Kugellager - verschraubt, Radachse verschraubt - gesichert, alle Teile aus Edelstahl rostfrei → Seite	AUSWAHLHILFE: <table border="0"> <tr> <td>leicht lenkend</td> <td><input type="checkbox"/></td> <td><input checked="" type="checkbox"/></td> <td><input checked="" type="checkbox"/></td> </tr> <tr> <td>verschleißarm</td> <td><input checked="" type="checkbox"/></td> <td><input type="checkbox"/></td> <td><input type="checkbox"/></td> </tr> <tr> <td>stoßfest</td> <td><input checked="" type="checkbox"/></td> <td><input type="checkbox"/></td> <td><input type="checkbox"/></td> </tr> <tr> <td>bodenschonend</td> <td><input type="checkbox"/></td> <td><input type="checkbox"/></td> <td><input checked="" type="checkbox"/></td> </tr> <tr> <td>witterungsbeständig</td> <td><input type="checkbox"/></td> <td><input type="checkbox"/></td> <td><input checked="" type="checkbox"/></td> </tr> </table>	leicht lenkend	<input type="checkbox"/>	<input checked="" type="checkbox"/>	<input checked="" type="checkbox"/>	verschleißarm	<input checked="" type="checkbox"/>	<input type="checkbox"/>	<input type="checkbox"/>	stoßfest	<input checked="" type="checkbox"/>	<input type="checkbox"/>	<input type="checkbox"/>	bodenschonend	<input type="checkbox"/>	<input type="checkbox"/>	<input checked="" type="checkbox"/>	witterungsbeständig	<input type="checkbox"/>	<input type="checkbox"/>	<input checked="" type="checkbox"/>
leicht lenkend	<input type="checkbox"/>	<input checked="" type="checkbox"/>	<input checked="" type="checkbox"/>																			
verschleißarm	<input checked="" type="checkbox"/>	<input type="checkbox"/>	<input type="checkbox"/>																			
stoßfest	<input checked="" type="checkbox"/>	<input type="checkbox"/>	<input type="checkbox"/>																			
bodenschonend	<input type="checkbox"/>	<input type="checkbox"/>	<input checked="" type="checkbox"/>																			
witterungsbeständig	<input type="checkbox"/>	<input type="checkbox"/>	<input checked="" type="checkbox"/>																			

Technische Details

ORDERNO (Artikel-nummer)	310X PT 50 V
WDAB (Rad-Ø A x Breite B / mm)	50x18
LC (Tragkraft / kg)	40
H (Bauhöhe H / mm)	75
TP (Plattengröße / mm)	60x60
HS (Lochabstand / mm)	40x40/46x46
HD (Loch-Ø / mm)	7
SR (Schwenkradius / mm)	52
WB (Radlager)	Polyamid-Gleitlager