

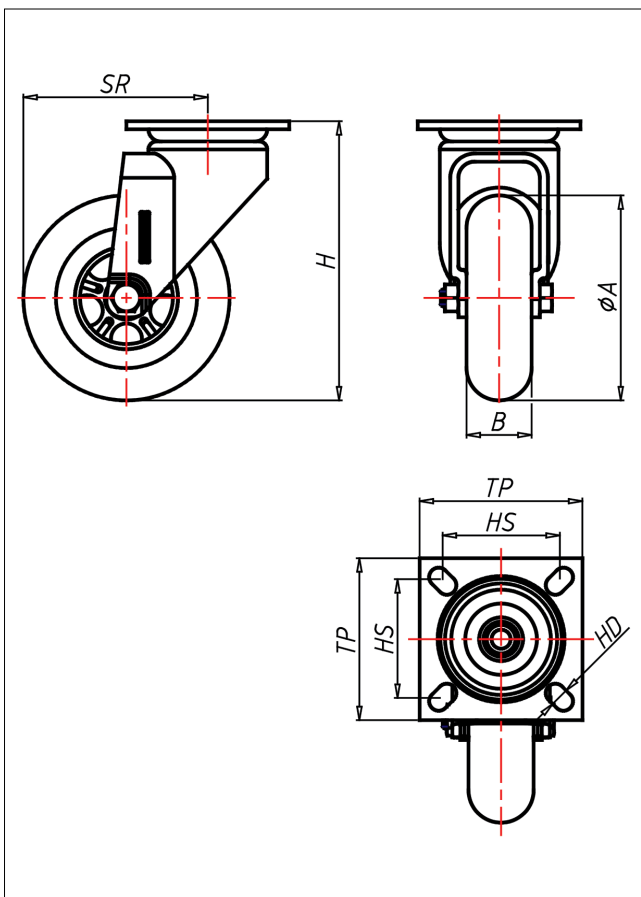

# 310X PT-V/SKA/TPKX

## Lenkrolle

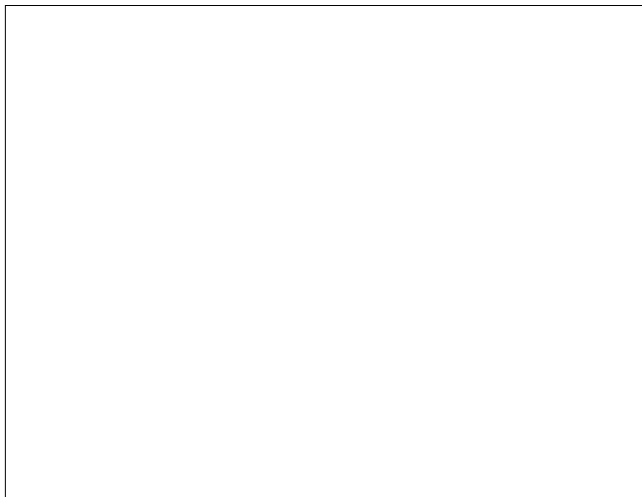

### 310XP-TP



LENKROLLE	LENKROLLE MIT TOTALFESTSTELLER	RAD SERIE SKA																				
 <ul style="list-style-type: none"> <li>geräuscharmer Lauf</li> <li>geringer Rollwiderstand</li> <li>abrieb- und reißfest</li> <li>hohe Stoßfestigkeit</li> <li>spurfrei</li> <li>sehr beständig gegen viele aggressive Medien</li> </ul> <p>Thermoplastisches Elastomer Felge Polyamid 6 → Seite 269</p> 	 <p><b>zweifaches Kugellager - verschraubt, Radachse verschraubt - gesichert, alle Teile aus Edelstahl rostfrei</b></p> <p>→ Seite</p>	 <p><b>AUSWAHLHILFE:</b></p> <table border="0"> <tr> <td>leicht lenkend</td> <td><input type="radio"/></td> <td><input checked="" type="radio"/></td> <td><input type="radio"/></td> </tr> <tr> <td>verschleißarm</td> <td><input type="radio"/></td> <td><input checked="" type="radio"/></td> <td><input type="radio"/></td> </tr> <tr> <td>stoßfest</td> <td><input checked="" type="radio"/></td> <td><input type="radio"/></td> <td><input type="radio"/></td> </tr> <tr> <td>bodenschonend</td> <td><input type="radio"/></td> <td><input checked="" type="radio"/></td> <td><input type="radio"/></td> </tr> <tr> <td>witterungsbeständig</td> <td><input type="radio"/></td> <td><input checked="" type="radio"/></td> <td><input type="radio"/></td> </tr> </table>	leicht lenkend	<input type="radio"/>	<input checked="" type="radio"/>	<input type="radio"/>	verschleißarm	<input type="radio"/>	<input checked="" type="radio"/>	<input type="radio"/>	stoßfest	<input checked="" type="radio"/>	<input type="radio"/>	<input type="radio"/>	bodenschonend	<input type="radio"/>	<input checked="" type="radio"/>	<input type="radio"/>	witterungsbeständig	<input type="radio"/>	<input checked="" type="radio"/>	<input type="radio"/>
leicht lenkend	<input type="radio"/>	<input checked="" type="radio"/>	<input type="radio"/>																			
verschleißarm	<input type="radio"/>	<input checked="" type="radio"/>	<input type="radio"/>																			
stoßfest	<input checked="" type="radio"/>	<input type="radio"/>	<input type="radio"/>																			
bodenschonend	<input type="radio"/>	<input checked="" type="radio"/>	<input type="radio"/>																			
witterungsbeständig	<input type="radio"/>	<input checked="" type="radio"/>	<input type="radio"/>																			

### Technische Details

<b>ORDERNO (Artikel-nummer)</b>	310X PT 75 SKA
<b>WDAB (Rad-Ø A x Breite B / mm)</b>	76x24
<b>LC (Tragkraft / kg)</b>	45
<b>H (Bauhöhe H / mm)</b>	103.5
<b>TP (Plattengröße / mm)</b>	60x60
<b>HS (Lochabstand / mm)</b>	40x40/46x46
<b>HD (Loch-Ø / mm)</b>	7
<b>SR (Schwenkradius / mm)</b>	67.5
<b>WB (Radlager)</b>	Ball bearing