

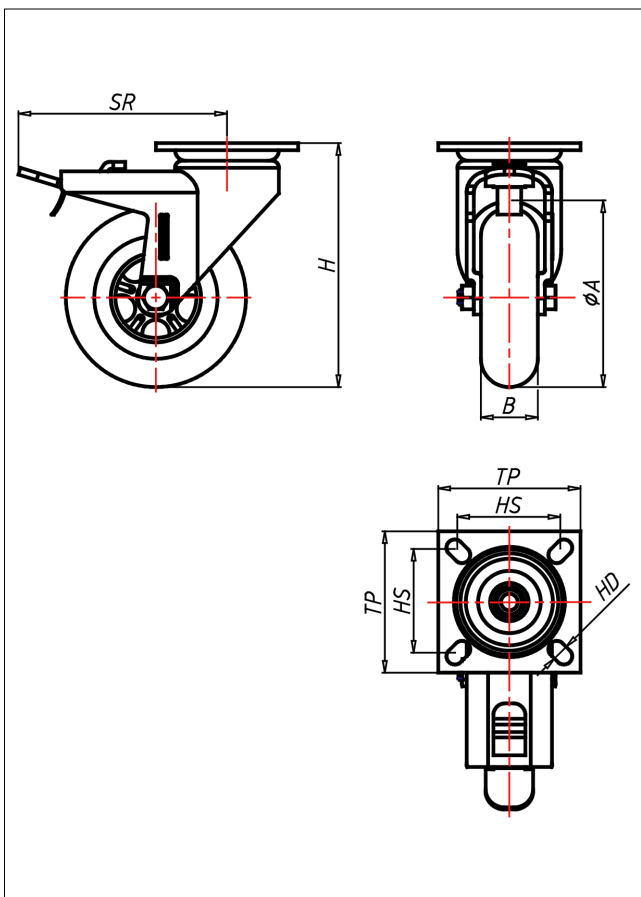

312X PT-V/SKA/TPKX

Lenkrolle mit Totalfeststeller

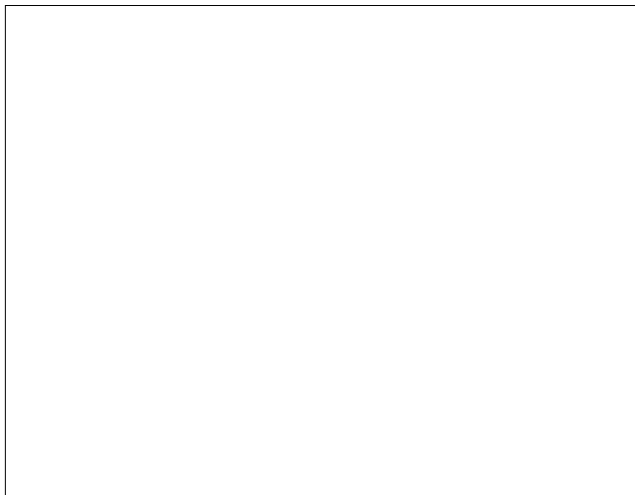

310XP-TP



LENKROLLE	LENKROLLE MIT TOTALFESTSTELLER	RAD SERIE SKA																				
<ul style="list-style-type: none"> • geräuscharmer Lauf • geringer Rollwiderstand • abrieb- und reißfest • hohe Stoßfestigkeit • spurfrei • sehr beständig gegen viele aggressive Medien Thermoplastisches Elastomer Felge Polyamid 6 → Seite 269	zweifaches Kugellager - verschraubt, Radachse verschraubt - gesichert, alle Teile aus Edelstahl rostfrei → Seite	AUSWAHLHILFE: <table border="0"> <tr> <td>leicht lenkend</td> <td>+</td> <td>+</td> <td>+</td> </tr> <tr> <td>verschleißarm</td> <td>x</td> <td>x</td> <td>x</td> </tr> <tr> <td>stoßfest</td> <td>x</td> <td>x</td> <td>x</td> </tr> <tr> <td>bodenschonend</td> <td>+</td> <td>+</td> <td>+</td> </tr> <tr> <td>witterungsbeständig</td> <td>+</td> <td>+</td> <td>+</td> </tr> </table>	leicht lenkend	+	+	+	verschleißarm	x	x	x	stoßfest	x	x	x	bodenschonend	+	+	+	witterungsbeständig	+	+	+
leicht lenkend	+	+	+																			
verschleißarm	x	x	x																			
stoßfest	x	x	x																			
bodenschonend	+	+	+																			
witterungsbeständig	+	+	+																			

Technische Details

ORDERNO (Artikel-nummer)	312X PT 75 TPKX
WDAB (Rad-Ø A x Breite B / mm)	75x25
LC (Tragkraft / kg)	45
H (Bauhöhe H / mm)	103
TP (Plattengröße / mm)	60x60
HS (Lochabstand / mm)	40x40/46x46
HD (Loch-Ø / mm)	7
SR (Schwenkradius / mm)	85
WB (Radlager)	Ball bearing