

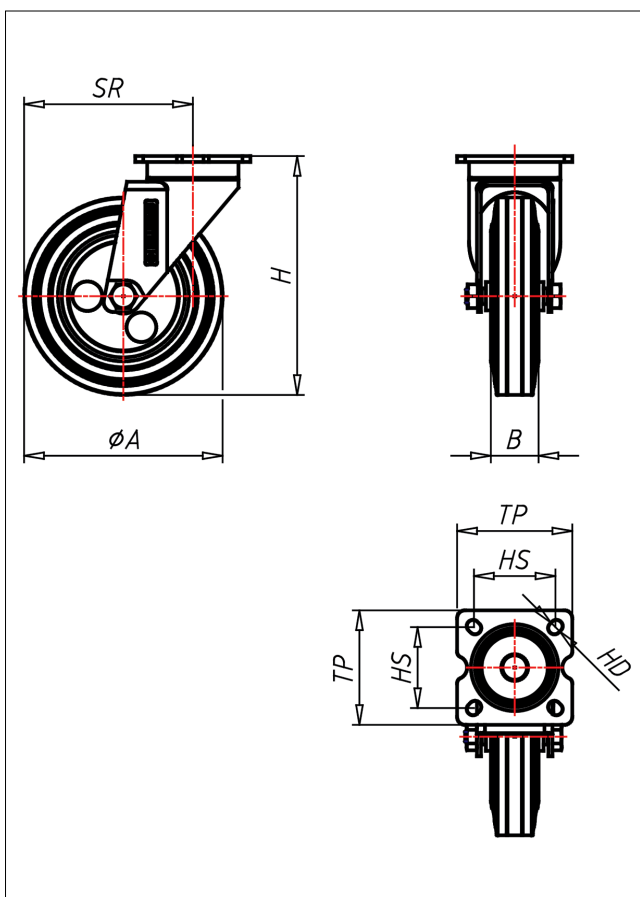

315 PT-EL

Lenkrolle



315P-EL



LENKROLLE	LENKROLLE MIT TOTALFESTSTELLER	BOCKROLLE																				
<ul style="list-style-type: none"> • elektrisch leitfähig • Widerstand <math><10^4 \Omega</math> • geräuscharmer Lauf • großer Fahrkomfort • beständig gegen verdünnte Säuren <p>Vollgummi oder TPE spurfrei Felge Stahlblech oder Polyamid 6 → Seite 267</p>	<p>zweifaches Kugellager $\varnothing 46 \text{ mm}$ - vernietet, Staubschutzring, Radachse verschraubt - gesichert, verzinkt - chromatiert → Seite</p>	<p>AUSWAHLHILFE:</p> <table border="0"> <tr><td>leicht lenkend</td><td><input checked="" type="checkbox"/></td><td><input checked="" type="checkbox"/></td><td><input checked="" type="checkbox"/></td></tr> <tr><td>verschleißarm</td><td><input checked="" type="checkbox"/></td><td><input checked="" type="checkbox"/></td><td><input checked="" type="checkbox"/></td></tr> <tr><td>stoßfest</td><td><input checked="" type="checkbox"/></td><td><input checked="" type="checkbox"/></td><td><input checked="" type="checkbox"/></td></tr> <tr><td>bodenschonend</td><td><input checked="" type="checkbox"/></td><td><input checked="" type="checkbox"/></td><td><input checked="" type="checkbox"/></td></tr> <tr><td>witterungsbeständig</td><td><input checked="" type="checkbox"/></td><td><input checked="" type="checkbox"/></td><td><input checked="" type="checkbox"/></td></tr> </table>	leicht lenkend	<input checked="" type="checkbox"/>	<input checked="" type="checkbox"/>	<input checked="" type="checkbox"/>	verschleißarm	<input checked="" type="checkbox"/>	<input checked="" type="checkbox"/>	<input checked="" type="checkbox"/>	stoßfest	<input checked="" type="checkbox"/>	<input checked="" type="checkbox"/>	<input checked="" type="checkbox"/>	bodenschonend	<input checked="" type="checkbox"/>	<input checked="" type="checkbox"/>	<input checked="" type="checkbox"/>	witterungsbeständig	<input checked="" type="checkbox"/>	<input checked="" type="checkbox"/>	<input checked="" type="checkbox"/>
leicht lenkend	<input checked="" type="checkbox"/>	<input checked="" type="checkbox"/>	<input checked="" type="checkbox"/>																			
verschleißarm	<input checked="" type="checkbox"/>	<input checked="" type="checkbox"/>	<input checked="" type="checkbox"/>																			
stoßfest	<input checked="" type="checkbox"/>	<input checked="" type="checkbox"/>	<input checked="" type="checkbox"/>																			
bodenschonend	<input checked="" type="checkbox"/>	<input checked="" type="checkbox"/>	<input checked="" type="checkbox"/>																			
witterungsbeständig	<input checked="" type="checkbox"/>	<input checked="" type="checkbox"/>	<input checked="" type="checkbox"/>																			

Technische Details

ORDERNO (Artikel-nummer)	315 PT 100 EL
WDAB (Rad- \varnothing A x Breite B / mm)	100x24
LC (Tragkraft / kg)	70
H (Bauhöhe H / mm)	121
TP (Plattengröße / mm)	58x58
HS (Lochabstand / mm)	40x40/42x42
HD (Loch- \varnothing / mm)	6.2
SR (Schwenkradius / mm)	85
WB (Radlager)	Kugellager