

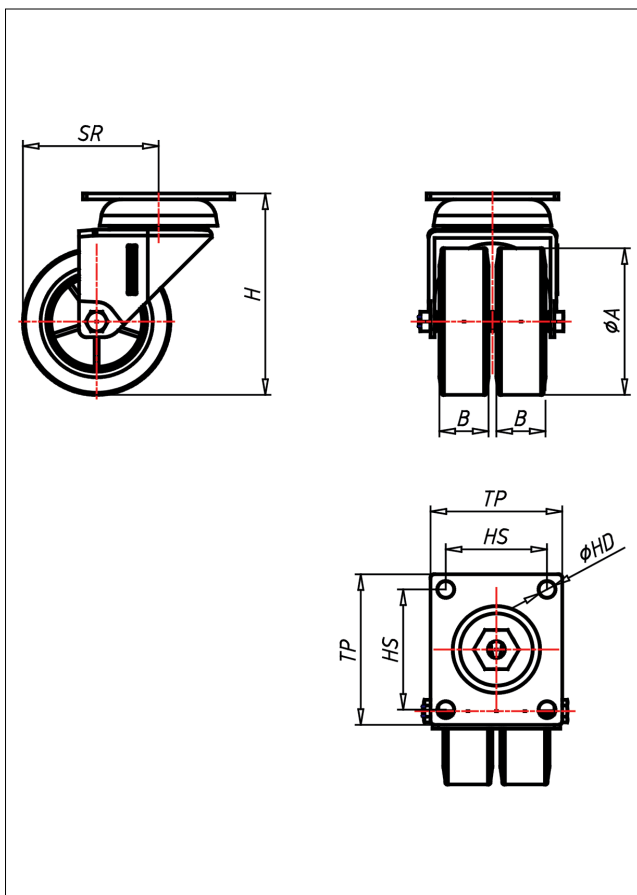

# 320 PT-VK/V/DK/TPK

## Lenkrolle



320P-D



LENKROLLE	LENKROLLE MIT TOTALFESTSTELLER																					
																						
<ul style="list-style-type: none"> <li>• geräuscharmer Lauf</li> <li>• geringer Rollwiderstand</li> <li>• abrieb- und reißfest</li> <li>• hohe Stoßfestigkeit</li> <li>• spurfrei</li> <li>• sehr beständig gegen viele aggressive Medien</li> </ul> Thermoplastisches Elastomer Felge Polyamid 6 → Seite 209	 <ul style="list-style-type: none"> <li>• zweifaches Kugellager - vernietet</li> <li>• Radachse verschraubt - gesichert</li> <li>• verzinkt-chromatiert</li> </ul> → Seite	AUSWAHLHILFE: <table border="0"> <tr> <td>leicht lenkend</td> <td>-</td> <td>+</td> <td>+</td> </tr> <tr> <td>verschleißarm</td> <td>-</td> <td>+</td> <td>+</td> </tr> <tr> <td>stoßfest</td> <td>-</td> <td>+</td> <td>+</td> </tr> <tr> <td>bodenschonend</td> <td>-</td> <td>+</td> <td>+</td> </tr> <tr> <td>witterungsbeständig</td> <td>-</td> <td>+</td> <td>+</td> </tr> </table>	leicht lenkend	-	+	+	verschleißarm	-	+	+	stoßfest	-	+	+	bodenschonend	-	+	+	witterungsbeständig	-	+	+
leicht lenkend	-	+	+																			
verschleißarm	-	+	+																			
stoßfest	-	+	+																			
bodenschonend	-	+	+																			
witterungsbeständig	-	+	+																			

### Technische Details

ORDERNO (Artikel-nummer)	320 PT 75 TPK
WDAB (Rad-Ø A x Breite B / mm)	75x25+25
LC (Tragkraft / kg)	90
H (Bauhöhe H / mm)	103
TP (Plattengröße / mm)	77x67
HS (Lochabstand / mm)	61.5x51.5
HD (Loch-Ø / mm)	8.5
SR (Schwenkradius / mm)	69
WB (Radlager)	Kugellager